

# Open Geospatial Consortium

Submission Date: 2017-03-24

Approval Date: 2017-06-02

Publication Date: 2017-08-16

External identifier of this OGC® document: <http://www.opengis.net/doc/standard/infragml/part4/1.0>

Internal reference number of this OGC® document: 16-104r2

Version: 1.0

Category: OGC® Encoding Standard

Editor: Paul Scarponcini

Contributors:

## OGC InfraGML 1.0: Part 4 – LandInfra Roads - Encoding Standard

### Copyright notice

Copyright © 2017 Open Geospatial Consortium  
To obtain additional rights of use, visit <http://www.opengeospatial.org/legal/>.

### Warning

This document is an OGC Member approved international standard. This document is available on a royalty free, non-discriminatory basis. Recipients of this document are invited to submit, with their comments, notification of any relevant patent rights of which they are aware and to provide supporting documentation.

Document type: OGC® Standard  
Document subtype:  
Document stage: Approved  
Document language: English

## License Agreement

Permission is hereby granted by the Open Geospatial Consortium, ("Licensor"), free of charge and subject to the terms set forth below, to any person obtaining a copy of this Intellectual Property and any associated documentation, to deal in the Intellectual Property without restriction (except as set forth below), including without limitation the rights to implement, use, copy, modify, merge, publish, distribute, and/or sublicense copies of the Intellectual Property, and to permit persons to whom the Intellectual Property is furnished to do so, provided that all copyright notices on the intellectual property are retained intact and that each person to whom the Intellectual Property is furnished agrees to the terms of this Agreement.

If you modify the Intellectual Property, all copies of the modified Intellectual Property must include, in addition to the above copyright notice, a notice that the Intellectual Property includes modifications that have not been approved or adopted by LICENSOR.

THIS LICENSE IS A COPYRIGHT LICENSE ONLY, AND DOES NOT CONVEY ANY RIGHTS UNDER ANY PATENTS THAT MAY BE IN FORCE ANYWHERE IN THE WORLD.

THE INTELLECTUAL PROPERTY IS PROVIDED "AS IS", WITHOUT WARRANTY OF ANY KIND, EXPRESS OR IMPLIED, INCLUDING BUT NOT LIMITED TO THE WARRANTIES OF MERCHANTABILITY, FITNESS FOR A PARTICULAR PURPOSE, AND NONINFRINGEMENT OF THIRD PARTY RIGHTS. THE COPYRIGHT HOLDER OR HOLDERS INCLUDED IN THIS NOTICE DO NOT WARRANT THAT THE FUNCTIONS CONTAINED IN THE INTELLECTUAL PROPERTY WILL MEET YOUR REQUIREMENTS OR THAT THE OPERATION OF THE INTELLECTUAL PROPERTY WILL BE UNINTERRUPTED OR ERROR FREE. ANY USE OF THE INTELLECTUAL PROPERTY SHALL BE MADE ENTIRELY AT THE USER'S OWN RISK. IN NO EVENT SHALL THE COPYRIGHT HOLDER OR ANY CONTRIBUTOR OF INTELLECTUAL PROPERTY RIGHTS TO THE INTELLECTUAL PROPERTY BE LIABLE FOR ANY CLAIM, OR ANY DIRECT, SPECIAL, INDIRECT OR CONSEQUENTIAL DAMAGES, OR ANY DAMAGES WHATSOEVER RESULTING FROM ANY ALLEGED INFRINGEMENT OR ANY LOSS OF USE, DATA OR PROFITS, WHETHER IN AN ACTION OF CONTRACT, NEGLIGENCE OR UNDER ANY OTHER LEGAL THEORY, ARISING OUT OF OR IN CONNECTION WITH THE IMPLEMENTATION, USE, COMMERCIALIZATION OR PERFORMANCE OF THIS INTELLECTUAL PROPERTY.

This license is effective until terminated. You may terminate it at any time by destroying the Intellectual Property together with all copies in any form. The license will also terminate if you fail to comply with any term or condition of this Agreement. Except as provided in the following sentence, no such termination of this license shall require the termination of any third party end-user sublicense to the Intellectual Property which is in force as of the date of notice of such termination. In addition, should the Intellectual Property, or the operation of the Intellectual Property, infringe, or in LICENSOR's sole opinion be likely to infringe, any patent, copyright, trademark or other right of a third party, you agree that LICENSOR, in its sole discretion, may terminate this license without any compensation or liability to you, your licensees or any other party. You agree upon termination of any kind to destroy or cause to be destroyed the Intellectual Property together with all copies in any form, whether held by you or by any third party.

Except as contained in this notice, the name of LICENSOR or of any other holder of a copyright in all or part of the Intellectual Property shall not be used in advertising or otherwise to promote the sale, use or other dealings in this Intellectual Property without prior written authorization of LICENSOR or such copyright holder. LICENSOR is and shall at all times be the sole entity that may authorize you or any third party to use certification marks, trademarks or other special designations to indicate compliance with any LICENSOR standards or specifications. This Agreement is governed by the laws of the Commonwealth of Massachusetts. The application to this Agreement of the United Nations Convention on Contracts for the International Sale of Goods is hereby expressly excluded. In the event any provision of this Agreement shall be deemed unenforceable, void or invalid, such provision shall be modified so as to make it valid and enforceable, and as so modified the entire Agreement shall remain in full force and effect. No decision, action or inaction by LICENSOR shall be construed to be a waiver of any rights or remedies available to it.

## Contents

|  |    |
|--|----|
| 1. Scope.....  | 8  |
| 2. Conformance.....  | 8  |
| 3. References.....   | 9  |
| 4. Terms and Definitions.....  | 9  |
| 5. Conventions .....   | 10 |
| 5.1 Abbreviations .....  | 10 |
| 5.2 UML Package and Class Diagrams.....                                      | 10 |
| 5.3 Requirements.....  | 10 |
| 6. InfraGML Parts.....   | 11 |
| 7. Requirements Classes for this Part .....                                  | 13 |
| 7.1 Structural Overview of Requirements Classes.....                         | 13 |
| 7.1.1 Requirement Classes Defined in This Part .....                         | 14 |
| 7.1.2 Dependent Requirement Classes Defined in Other Parts .....             | 15 |
| 7.1.3 Other Standards upon which the Requirement Classes of this Part Depend | 15 |
| 7.2 Requirements Class: Road .....   | 16 |
| 7.2.1 Implementation decisions regarding OGC 15-111r1 UML.....               | 16 |
| 7.2.2 Specific Requirements for this Requirements Class.....                 | 16 |
| 7.2.3 StringLine geometry .....  | 18 |
| 7.2.4 Road with Alignment Example (informative) .....                        | 18 |
| 7.3 Requirements Class: RoadCrossSection .....                               | 29 |
| 7.3.1 Implement decisions regarding OGC 15-111r1 UML.....                    | 29 |
| 7.3.2 Specific Requirements for this Requirements Class.....                 | 29 |
| 7.3.3 Road with Alignment Example Continued (informative).....               | 30 |
| 8. Media Types for any data encoding(s).....                                 | 34 |

|   |    |
|---|----|
| Annex A: Conformance Class Abstract Test Suite (Normative)..... | 35 |
| A.1 Conformance class: Road.....                                | 35 |
| A.2 Conformance class: RoadCrossSection.....                    | 35 |
| Annex B: Sample XML (Informative).....                          | 37 |
| B.1 Complete Road (less Cross Sections) XML.....                | 37 |
| B.2 Complete Road Cross Section XML.....                        | 43 |
| Annex C: Revision history .....                                 | 48 |
| Annex D: Bibliography .....                                     | 49 |

## Figures

|   |    |
|---|----|
| Figure 1. InfraGML Part Dependencies.....                                 | 12 |
| Figure 2. LandInfra Requirements Classes grouped into InfraGML Parts..... | 13 |
| Figure 3. Requirements Classes for this Part and their Dependencies ..... | 14 |
| Figure 4. Two Lane Road example.....                                      | 18 |
| Figure 5. Alignment Plan and Profile views.....                           | 19 |
| Figure 6. Pavement as a RoadElement .....                                 | 21 |
| Figure 7. Pavement RoadElement PolyfaceMesh.....                          | 22 |
| Figure 8. Pavement (Top) Surface Representation .....                     | 25 |
| Figure 9. Pavement Triangulated (Top) Surface.....                        | 26 |
| Figure 10. Pavement StringLine Representation .....                       | 27 |
| Figure 11. Pavement StringLines.....                                      | 28 |
| Figure 12. Pavement CrossSection Representation .....                     | 31 |
| Figure 13. Pavement CrossSectionComponent.....                            | 31 |

## Tables

|   |    |
|---|----|
| Table 1. InfraGML Road XML elements with corresponding LandInfra UML classes .                  | 17 |
| Table 2. PolyfaceMesh indexed Point Coordinates .....   | 22 |
| Table 3. InfraGML Road Cross Section XML elements with corresponding LandInfra UML classes..... | 30 |
| Table 4. Pavement CrossSectionComponent CrossSectionPoints.....                                 | 32 |

## **i. Abstract**

This OGC InfraGML Encoding Standard presents the implementation-dependent, GML encoding of concepts supporting land and civil engineering infrastructure facilities specified in the OGC Land and Infrastructure Conceptual Model Standard (LandInfra), OGC 15-111r1. Conceptual model subject areas include land features, facilities, projects, alignment, road, railway, survey (including equipment, observations, and survey results), land division, and condominiums.

InfraGML is published as a multi-part standard. This Part 4 addresses the Road and RoadCrossSection Requirements Class from LandInfra.

## **ii. Keywords**

The following are keywords to be used by search engines and document catalogues.

OGC document, LandInfra, InfraGML, infrastructure, civil, road, roadway design, cross sections, stringlines

## **iii. Preface**

In order to achieve consensus on the concepts supporting land and civil engineering infrastructure facilities, a UML Conceptual Model, LandInfra, was approved as an OGC standard in August, 2016. This model provides a unifying basis for encodings including but not limited to InfraGML, including similar work in buildingSMART International. It can also provide a framework for discussing how other software standards relate to LandInfra.

As an OGC standard, LandInfra follows the OGC modular specification standard, OGC 08-131r3. Because of the breadth of LandInfra, its subject areas are divided into separate Requirements Classes. This InfraGML encoding similarly is divided into Requirements Classes which are then grouped into Parts. A Part may address multiple LandInfra Requirements Classes but each Requirements Class is addressed in a single part. Because Requirements Classes may depend on other Requirements Classes (see LandInfra Figure 1, “Requirements Classes as UML Packages with their dependencies”), the reader of this InfraGML Part may need to conform to Requirements Classes in other Parts as well.

Note that this InfraGML encoding standard is a target of LandInfra and therefore this standard conforms to the Requirements Classes in LandInfra. On the other hand, an application claiming conformance to this InfraGML encoding standard must conform to the Requirements Classes contained in this InfraGML standard.

There are several reasons for separating InfraGML into Parts. Because they are likely to have separate authors, the rate at which each Part is completed may vary. It would not be advisable to wait until all Parts complete before any can be released as separate OGC standards. Multiple Parts will also allow each subject to have its own standards life cycle. One Part can be updated independent of other Parts, subject to dependency

constraints. And of course, it should be easier for the application software developer to only deal with Parts relevant to their application.

Attention is drawn to the possibility that some of the elements of this document may be the subject of patent rights. The Open Geospatial Consortium shall not be held responsible for identifying any or all such patent rights.

*Recipients of this document are requested to submit, with their comments, notification of any relevant patent claims or other intellectual property rights of which they may be aware that might be infringed by any implementation of the standard set forth in this document, and to provide supporting documentation.*

#### **iv. Submitting organizations**

The following organizations submitted this Document to the Open Geospatial Consortium (OGC):

Bentley Systems, Inc.

Leica Geosystems

Swedish Transport Administration

Trimble Inc.

Autodesk

#### **v. Submitters**

All questions regarding this submission should be directed to the editor or the submitters:

| <b>Name</b>                         | <b>Affiliation</b>               |
|-------------------------------------|----------------------------------|
| Paul Scarponcini, SWG chair         | Bentley Systems, Inc.            |
| Hans-Christoph Gruler, SWG co-chair | Leica Geosystems                 |
| Peter Axelsson                      | Swedish Transport Administration |
| Lars Wikström                       | Swedish Transport Administration |
| Leif Granholm                       | Trimble Inc.                     |
| Johnny Jensen                       | Trimble Inc.                     |
| Thomas Liebich                      | buildingSMART International      |
| Orest Halustchak                    | Autodesk                         |

## 1. Scope

InfraGML is a GML encoding standard of the LandInfra Conceptual Model standard, OGC 15-111r1. InfraGML is provided as a set of individual though inter-dependent Parts, each of which is a GML standard.

The overall scope of this InfraGML Encoding Standard is infrastructure facilities and the land on which they are constructed. Also included is the surveying necessary for the setting out and as-built recording of these facilities and land interests. Primarily having a civil engineering point of view, InfraGML is relevant across all life cycle phases of a facility. Subject areas include land features, facilities, projects, alignment, road, railway, survey (including equipment, observations, and survey results), land division, and condominiums.

The scope of this Part 4 of InfraGML addresses the following subject area(s): roads, road cross sections. The InfraGML Road and RoadCrossSection Requirements Classes are included. It is optional in that an application can conform to InfraGML without supporting it, for example by only supporting the Survey Requirements Classes in Part 6. However, to claim support for Road, an application must also support the InfraGML Core, Facility, and LandFeature Requirements Classes and may choose to support the Alignment Requirements Class. To claim support for RoadCrossSection, an application must also support the InfraGML Road, Facility, LandFeature, and Core Requirements Classes and may choose to support the Alignment Requirements Class.

## 2. Conformance

The InfraGML encoding standard defines requirements, grouped into Requirements Classes, for applications which read and write information about infrastructure facilities and the land on which they are constructed, including the surveying necessary for the setting out and as-built recording of these facilities and land interests.

The OGC modular specification (OGC 08-131r3) defines “standardization target” as the entity to which requirements of a standard apply. It further notes that the standardization target is the entity which may receive a certificate of conformance for a requirements class. The standardization target type for this standard is therefore:

- software applications which read/write data instances, i.e. XML documents that encode land, infrastructure facility, and survey data for exchange

Conformance with this standard shall be checked using all the relevant tests specified in Annex A (normative) of this document. The framework, concepts, and methodology for



testing, and the criteria to be achieved to claim conformance are specified in the OGC Compliance Testing Policies and Procedures and the OGC Compliance Testing web site<sup>1</sup>.

In order to conform to this OGC encoding standard, a standardization target shall choose to implement the core conformance class and any of the other conformance classes with their dependencies. Conformance classes are based on Requirements Classes which are specified in this and possibly other Parts of the InfraGML standard.

All requirements classes and conformance classes described in this document are owned by the standard(s) identified. Note that Conformance Classes for this Part of InfraGML may require conformance with Conformance Classes from other Parts of InfraGML.

### 3. References

The following normative documents contain provisions that, through reference in this text, constitute provisions of this Part of InfraGML. For dated references, subsequent amendments to, or revisions of, any of these publications do not apply. For undated references, the latest edition of the normative document referred to applies.

OGC: OGC 07-036, *OpenGIS® Geography Markup Language (GML) Encoding Standard*, v3.2.1, 2007

OGC: OGC 10-129r1, *OGC® Geography Markup Language (GML) — Extended schemas and encoding rules*, v3.3, 2012

OGC: OGC 15-111r1, *OGC Land and Infrastructure Conceptual Model Standard (LandInfra)*, v1.0, 2016.

OGC: OGC 16-100, *OGC InfraGML 1.0: Part 0 – LandInfra Core – Encoding Standard*, v1.0, 2017

OGC: OGC 16-101, *OGC InfraGML 1.0: Part 1 – LandInfra Land Features – Encoding Standard*, v1.0, 2017

OGC: OGC 16-102, *OGC InfraGML 1.0: Part 2 – LandInfra Facilities and Projects – Encoding Standard*, v1.0, 2017

### 4. Terms and Definitions

This document uses the terms defined in Sub-clause 5.3 of [OGC 06-121r8], which is based on the ISO/IEC Directives, Part 2, Rules for the structure and drafting of

---

<sup>1</sup> [www.opengeospatial.org/cite](http://www.opengeospatial.org/cite)

International Standards. In particular, the word “shall” (not “must”) is the verb form used to indicate a requirement to be strictly followed to conform to this standard.

The LandInfra standard contains a long list of terms and definitions relevant to the scope of InfraGML. As these will not be repeated here, the reader is directed to Clause 4 of LandInfra.

## **5. Conventions**

### **5.1 Abbreviations**

In this document the following abbreviations and acronyms are used or introduced:

|     |  |
|-----|--|
| bSI | buildingSMART International                    |
| GML | Geography Markup Language                      |
| ISO | International Organization for Standardization |
| OGC | Open Geospatial Consortium                     |
| UML | Unified Modeling Language                      |
| XML | eXtensible Markup Language                     |

### **5.2 UML Package and Class Diagrams**

The LandInfra standard contains UML diagrams for the concepts supported by InfraGML. As these will not be repeated here, the reader is directed to Clause 7 of LandInfra. UML will only appear in InfraGML in the rare cases where LandInfra is extended by InfraGML.

### **5.3 Requirements**

When referred to in a Requirement or Requirements Class, the boxes contained in the LandInfra UML figures may all be called “Classes” even if they are data types, enumerations, code lists, unions etc. In most cases, these will be encoded as XML elements in InfraGML.

When an InfraGML Requirement states that “A conforming application shall support the [Requirements Class] XML elements listed in Table <n> in accordance with the GML XSD in this standard.”, the XSD was developed to support the UML for the corresponding LandInfra Requirements Class as follows:

- a) all classes shown as blue boxes for the corresponding LandInfra Requirements Class UML diagrams;
- b) all attributes, attribute cardinalities, and attribute data types of these classes (usually shown in subsequent diagrams);

- c) all associations, navigation, roles, and role cardinalities connected to the blue classes;
- d) all classes shown as beige boxes (another Requirements Class) in the diagrams connected to the blue box classes by association or used as attribute data types; and
- e) all classes shown as pink boxes (another Standard) in the figure connected to the blue box classes by association or used as attribute data types.

Note that, in rare cases, the OGC 15-111r1 UML may be altered. In such cases, the alterations are declared in the first subclause of each Requirements Class, entitled “Implementation decisions regarding OGC 15-111r1 UML”. Logical Model UML diagrams may be included if the implementation constraints of GML (or XML) dictate that the Conceptual Model cannot be implemented directly as shown in OGC 15-111r1.

In most cases, the InfraGML XML derived from the LandInfra UML follows the rules in OGC 07-036, GML, Annex E, UML-to-GML application schema encoding rules.

The only normative version of the GML XSD (XML schema definition) for all Parts of the InfraGML Encoding Standard is available from the official OGC XML schema repository at <http://schemas.opengis.net>. Any occurrences of all or part of this XSD contained within this document are to be considered to be informative only.

The URI base for the LandInfra Conceptual Model standard is <http://www.opengis.net/spec/landinfra/1.0>. All URIs of Requirements Classes, Requirements, and Conformance Classes contained in that standard are relative to this base.

The URI base for this InfraGML encoding standard is <http://www.opengis.net/spec/infragml/part4/1.0>. All URIs of Requirements Classes, Requirements, and Conformance Classes contained in this standard are relative to this base.

## 6. InfraGML Parts

The InfraGML encoding standard has been divided into Parts. These Parts enable the grouping of LandInfra subject areas (Requirements Classes) into individual OGC encoding standards. All of these InfraGML encoding standards have a similar name: “OGC 16-10n, OGC® InfraGML 1.0: Part n - <part name> Encoding Standard”, where Part numbers and names are as follows:

| n | <part name>                       |
|---|-----------------------------------|
| 0 | LandInfra Core                    |
| 1 | LandInfra LandFeatures            |
| 2 | LandInfra Facilities and Projects |

|   |                        |
|---|------------------------|
| 3 | LandInfra Alignments   |
| 4 | LandInfra Roads        |
| 5 | LandInfra Railways     |
| 6 | LandInfra Survey       |
| 7 | LandInfra LandDivision |

Some InfraGML Parts depend upon other parts:

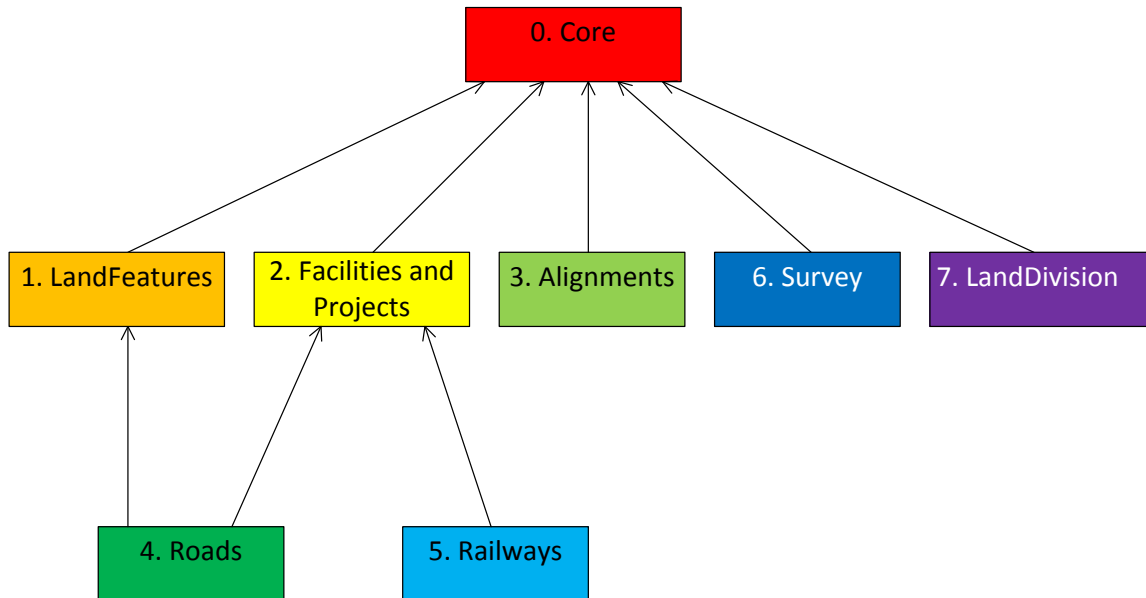

Figure 1. InfraGML Part Dependencies

The boxes above represent InfraGML Parts. Arrows show Part dependencies.

The Part dependencies derive from the dependencies of the InfraGML Requirements Classes contained in these Parts. The reader should rely more on the InfraGML Requirements Class dependencies and only use the Part dependencies as a guide for knowing which InfraGML Part standards to consider.

InfraGML Parts include the following LandInfra 1.0 Requirements Classes (UML Packages):

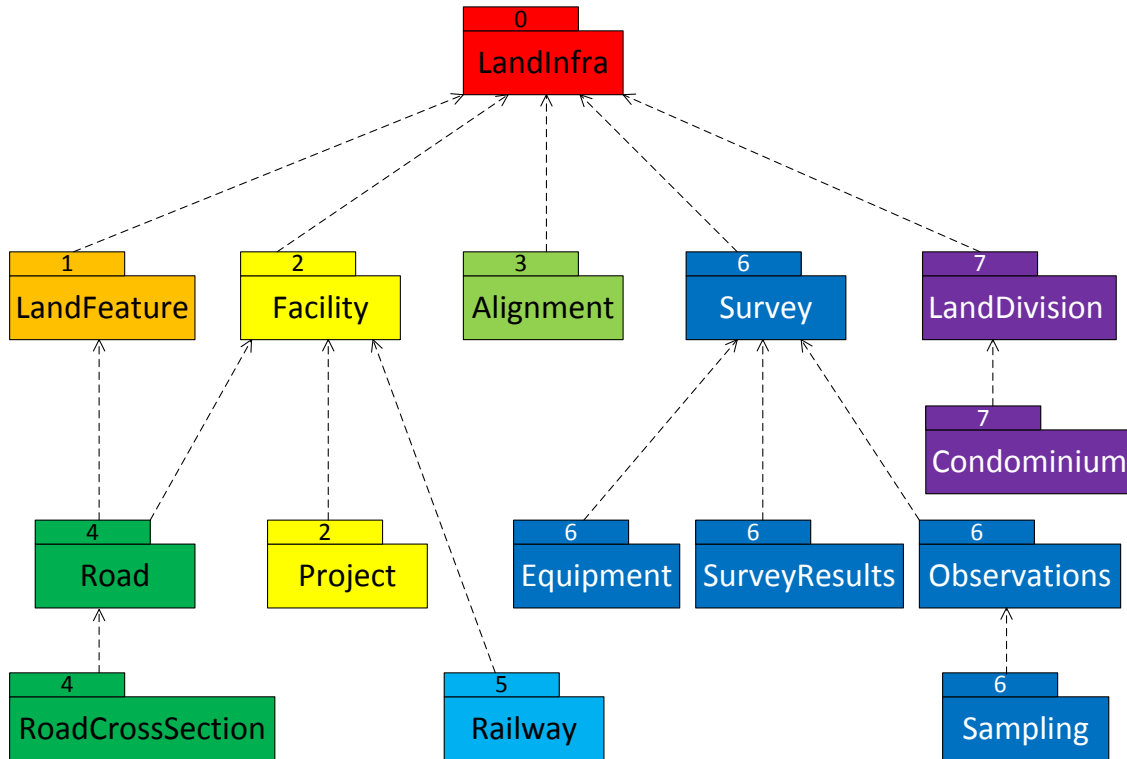

Figure 2. LandInfra Requirements Classes grouped into InfraGML Parts

The boxes above and their names represent LandInfra Requirements Classes. The numbers are InfraGML Part numbers. Dependency arrows shown above are dependencies between LandInfra Requirements Classes.

## 7. Requirements Classes for this Part

### 7.1 Structural Overview of Requirements Classes

The Requirements Classes for this Part of the InfraGML encoding standard (shown in blue in Figure 3 below) are defined in this Clause 7. Requirements Classes from other Parts upon which this Part's Requirements Classes are dependent (shown in beige in Figure 3 below) are listed here but defined in the documentation of their respective Parts. External OGC and ISO standards on which Requirements Classes in this Standard depend (shown in pink in Figure 3 below) are also listed. Below is a brief summary of the function of each of these Requirements Classes.

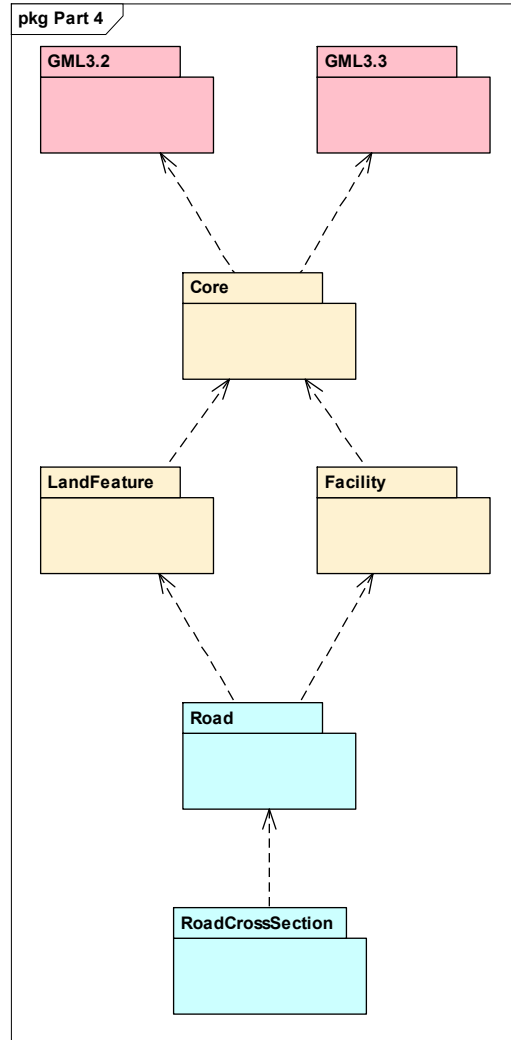

Figure 3. Requirements Classes for this Part and their Dependencies

### 7.1.1 Requirement Classes Defined in This Part

#### Road

The Road Requirements Class supports those use cases in which a designer wishes to exchange the output of the design with someone who is likely to use it for purposes other than completing the road design. Consequently, the Road Requirements Class includes several alternative ways for representing a design such as with 3D RoadElements, 3D StringLines (aka profile views, longitudinal breaklines, long sections), and 3D surfaces and layers, as well as collections of these.

#### RoadCrossSection

The RoadCrossSection Requirements Class extends the Road Requirements Class by adding the 2D CrossSection alternative way of representing a design, as well as collections of these.

### **7.1.2 Dependent Requirement Classes Defined in Other Parts**

The Requirements Classes defined in this Part are dependent on the following Requirements Classes from other Parts.

#### **Part 0. LandInfra Core**

LandInfra is the core Requirements Class and is the only mandatory Requirements Class. This class contains information about the Land and Infrastructure dataset that can contain information about facilities, land features, land division, documents, survey marks, surveys, sets, and feature associations. LandInfra also contains the definition of types common across other Requirements Classes, such as the Status CodeList.

#### **Part 1. LandInfra LandFeature**

Features of the land, such as naturally occurring water features and vegetation are specified in the LandFeature Requirements Class as land features. Also included are models of the land surface and subsurface layers. Improvements to the land such as the construction of an embankment or the planting of landscape material are considered to be part of Site Facilities in the Facility Requirements Class.

#### **Part 2. LandInfra Facility**

Facilities include collections of buildings and civil engineering works and their associated siteworks. The Facilities Requirements Class includes the breakdown of facilities into discipline specific facility parts and introduces the notion of elements which make up these parts. The Facilities Requirements Class only provides general support for facilities themselves, allowing subsequent Requirements Classes to focus on specific types of the parts that make up facilities, such as road and railway. This Requirements Class is optional in order to allow for the condition where all of the LandInfra dataset information is not facility related, such as one containing only survey or land division information.

### **7.1.3 Other Standards upon which the Requirement Classes of this Part Depend**

For external OGC and ISO standards on which Requirements Classes in this Standard depend, a brief summary of the function of each of these Standards is described below.

#### **GML 3.2**

OGC 07-036, OpenGIS® Geography Markup Language (GML) Encoding Standard, v3.2 provides most of the geometry types (e.g., Point, LineString, Polygon) used for spatial representations in this Standard. Defines Coordinate Reference Systems. Supports the General Feature Model upon which this Standard is based.

### GML 3.3

OGC 10-129r1, OGC® Geography Markup Language (GML) — Extended schemas and encoding rules, v3.3 defines the linear referencing concepts (e.g., linear element, distance along, Linear Referencing Methods) used for linearly referenced locations in this Standard.

#### 7.2 Requirements Class: Road

| Requirements Class |   |
|--------------------|---|
| <b>/req/road</b>   |   |
| Target type        | Conforming application                          |
| Name               | Road  |
| Dependency         | <b>/req/land-feature</b> (from InfraGML Part 1) |
| Dependency         | <b>/req/facility</b> (from InfraGML Part 2)     |
| Requirement        | <b>/req/road/elements</b>                       |
| Requirement        | <b>/req/road/alignment</b>                      |

##### 7.2.1 Implementation decisions regarding OGC 15-111r1 UML

The following implementation decisions have been made regarding the OGC 15-111r1 Road Requirements Class UML:

1. In agreement with bSI, the geometry of a StringLine has been expanded beyond LineString to optionally include AlignmentCurve, if the application supports the Alignment Requirements Class from LandInfra Part 3 (where AlignmentCurve is defined). See 7.2.3. However, a LineString geometry is still required.
2. Because the Feature.FeatureID attribute was dropped from Core (see Part 0), Road.roadID has been added. Because Element was removed from Part 2 Facilities and Projects, Road.roadElementID has been added. IDs have also been added for RoadElementSet, StringLine, StringLineSet, Surface, and SurfaceSet.

##### 7.2.2 Specific Requirements for this Requirements Class

|                    |   |
|--------------------|---|
| <b>Requirement</b> | <b>/req/road/elements</b><br><br>A conforming application shall support the Road XML elements listed in Table 1 in accordance with the GML XSD specified in <a href="http://schemas.opengis.net/infragml/part4/1.0/road.xsd">http://schemas.opengis.net/infragml/part4/1.0/road.xsd</a> . |
|--------------------|---|

An application conforming to this standard shall support the Road XML elements listed below in Table 1 in accordance with the GML XSD specified in <http://schemas.opengis.net/infragml/part4/1.0/road.xsd>. Road XML element names are



shown with a XML namespace prefix of “lifr”. Corresponding LandInfra UML classes are shown with their LandInfra Requirements Class prefix of “Road”.

| InfraGML XML element | LandInfra UML Class  |
|----------------------|----------------------|
| lifr:Road            | Road::Road           |
| lifr:RoadElement     | Road::RoadElement    |
| lifr:RoadElementSet  | Road::RoadElementSet |
| lifr:StringLine      | Road::StringLine     |
| lifr:StringLineSet   | Road::StringLineSet  |
| lifr:Surface         | Road::Surface        |
| lifr:SurfaceSet      | Road::SurfaceSet     |

*Table 1. InfraGML Road XML elements with corresponding LandInfra UML classes*

A Road FacilityPart can be represented in any of four different ways: as RoadElements, Surfaces, StringLines, or RoadCrossSections (see the RoadCrossSection Requirements Class in 7.3 for the RoadCrossSections representation). These are four different views of the same Road: as a solid (typically), as faceted (triangular) surfaces, as lines running longitudinally at key parts of the Road, and as 2D views cut perpendicular to the Road centerline, respectively. An application conforming to this Road Requirements Class can include any of the first three representations, singularly or in combination. An application conforming to the RoadCrossSection Requirements Class can also include the fourth representation alone or in combination with any of the other three. It is up to the application to ensure consistency between multiple representations of the same Road – InfraGML independently supports all four representations, but makes no assurances about consistency between them.

The four representations can be specified relative to some linear element, in accordance with OGC Abstract Specification Topic 19, Linear Referencing. If the application supports the InfraGML Alignment Requirements Class, then an Alignment can serve as the linearly locating linear element.

|                    |  |
|--------------------|--|
| <b>Requirement</b> | <p><b><i>/req/road/alignment</i></b></p> <p>If an application allows the linear element used for locating RoadElements to be an Alignment, or if it allows the StringLine curve geometry to be of type AlignmentCurve, then that application shall support the Alignment Requirements Class.</p> |
|--------------------|--|

### 7.2.3 StringLine geometry

The initial geometry type specified for StringLines in 15-111r1 was LineString. Since then, bSI has suggested expanding this to include AlignmentCurves. To maintain harmony, a second geometry type is added to StringLine:

**alternativeGeometry:** optional geometry as an AlignmentCurve

### 7.2.4 Road with Alignment Example (informative)

The Two Lane Road example in OGC 15-111r1, Clause 7.6.8, [LandInfra] RoadCrossSection Requirements Class is the basis for the Road with Alignment example. Attention will be focused only on the top pavement layer. Figure 4 shows two cross sections based on the Two Lane Road with the top pavement layer between them.

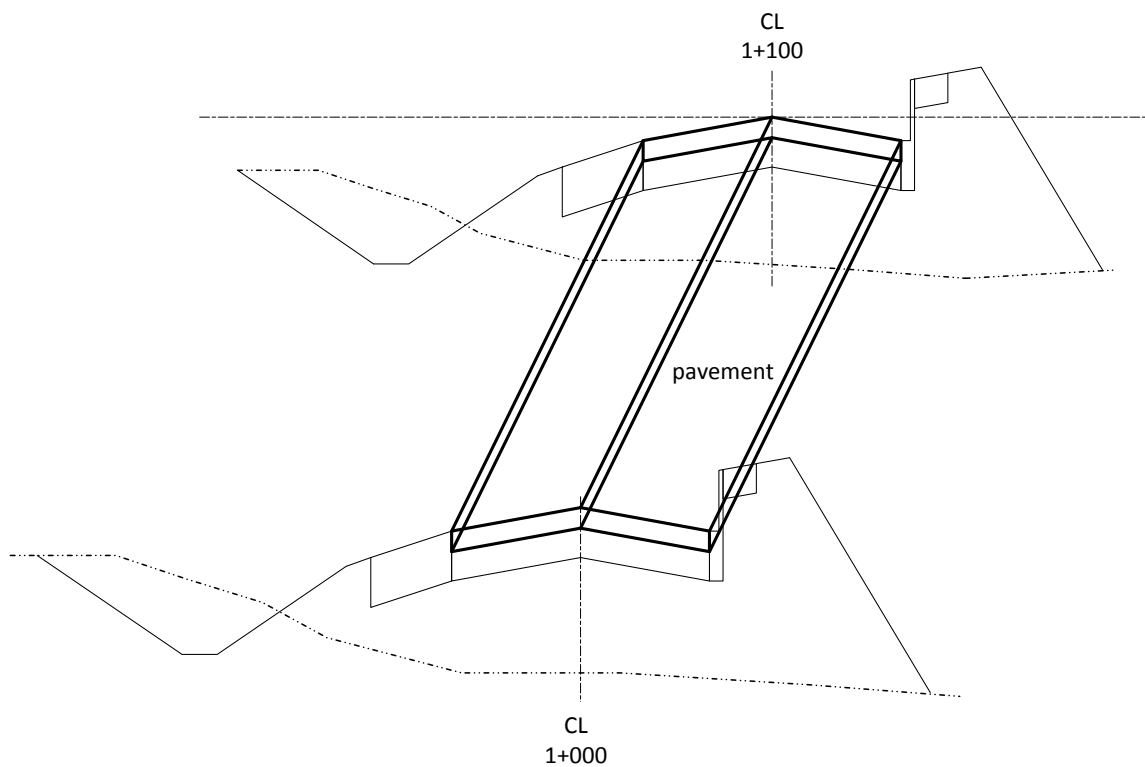

Figure 4. Two Lane Road example

#### 7.2.4.1 Alignment

The simple Alignment shown in Figure 5 is used for locating the example road. It is specified by a single lineSegment Alignment2DHorizontal and a single line Alignment2DVertical. In the horizontal view, the Alignment goes from (0, 1000) to (0, 1100). The Alignment defaultLRM is stationing with measures from the start in meters. A station value of 1+000 is represented in the GML without the “+” sign as 1000. The startValue is 1+000 and the overall length of the Alignment is 100 meters. (See Part 3 Alignment for a more complex Alignment example).

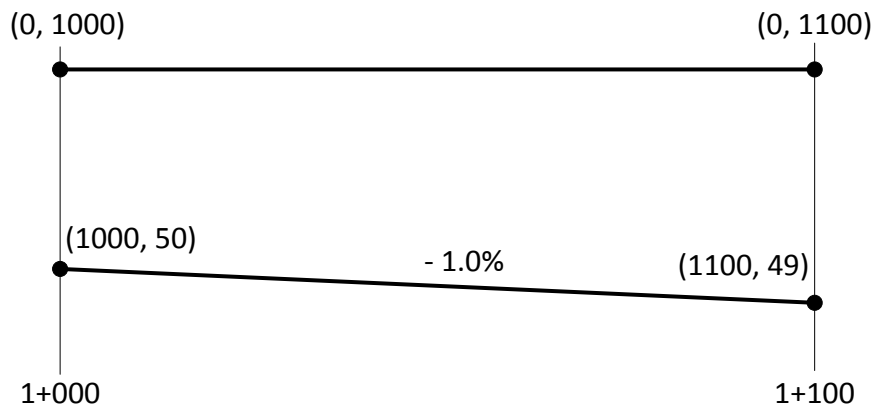

Figure 5. Alignment Plan and Profile views

The GML for the Alignment would be:

```

<feature>
  <lia:Alignment gml:id="a1">
    <lia:alignmentID>
      <lia:identifier>Alignment1</lia:identifier>
    </lia:alignmentID>
    <lia:geometry>
      <lia:AlignmentCurve gml:id="ac1">
        <lia:horizontal>
          <lia:Alignment2DHorizontal gml:id="ah1">
            <lia:location>road centerline</lia:location>
            <lia:description></lia:description>
            <lia:state>proposed</lia:state>
            <lia:segment>
              <lia:tangentialContinuity>true</lia:tangentialContinuity>
              <lia:geometry>
                <lia:lineSegment>
                  <gml:pos>0 1000</gml:pos>
                  <gml:pos>0 1100</gml:pos>
                </lia:lineSegment>
              </lia:geometry>
            </lia:segment>
          </lia:Alignment2DHorizontal>
        </lia:horizontal>
        <lia:vertical>
          <lia:Alignment2DVertical gml:id="av1">
            <lia:location>road centerline</lia:location>
            <lia:description></lia:description>
            <lia:state>proposed</lia:state>
            <lia:segments>
              <lia:tangentialContinuity>true</lia:tangentialContinuity>
              <lia:startDistAlong gml:id="sda1">
                <gmlr:distanceAlong>1000</gmlr:distanceAlong>
              </lia:startDistAlong>
              <lia:startHeight uom="m">50</lia:startHeight>
              <lia:startGradient>-1.0</lia:startGradient>
              <lia:horizontalLength uom="m">100</lia:horizontalLength>
            </lia:segments>
          </lia:Alignment2DVertical>
        </lia:vertical>
      </lia:AlignmentCurve>
    </lia:geometry>
  </lia:Alignment>
</feature>

```

```

        </lia:segments>
        <lia:measuredAlong xlink:href="ah1"></lia:measuredAlong>
        </lia:Alignment2DVertical>
        </lia:vertical>
        </lia:AlignmentCurve>
        </lia:geometry>
        </lia:Alignment>
    </feature>

```

The GML which enables alignment ‘a1’ to be measurable along as a linear element would also include:

```

<linearElement>
  <LinearElement gml:id="le1">
    <gmlr:feature xlink:href="a1" xlink:title="alignment a1">
      </gmlr:feature>
      <gmlr:defaultLRM xlink:href="lrm1"/>
      <gmlr:measure uom="m">100</gmlr:measure>
    </LinearElement>
  </linearElement>

```

Next, the GML which defines the Road FacilityPart of the campus Facility would be:

```

<feature>
  <lif:Facility gml:id="fac1">
    <lif:facilityID>
      <lif:identifier>101</lif:identifier>
    </lif:facilityID>
    <lif:type>campus</lif:type>
    <lif:status xlink:href="http://example.com/status#planned"
      xlink:title="Planned"/>
    <lif:footprint xlink:href="poly1" xlink:title="Polygon">
      </lif:footprint>
    <lif:part xlink:href="r1"></lif:part>
  </lif:Facility>
</feature>
<feature>
  <lifr:Road gml:id="r1">
    <lif:facilityPartID>
      <lif:identifier>Road1</lif:identifier>
    </lif:facilityPartID>
    <lif:type xlink:href="http://example.com/facilityPartType#road"
      xlink:title="Road"/>
    <lif:status xlink:href="http://example.com/status#designed"
      xlink:title="Designed"/>
    <lifr:roadID>
      <lifr:identifier>TwoLaneRoad</lifr:identifier>
    </lifr:roadID>
    <lifr:approximateWidth uom="m">13</lifr:approximateWidth>
  </lifr:Road>
</feature>

```

### 7.2.4.2 RoadElement Representation

Figure 6 shows the top pavement layer represented as a single RoadElement.

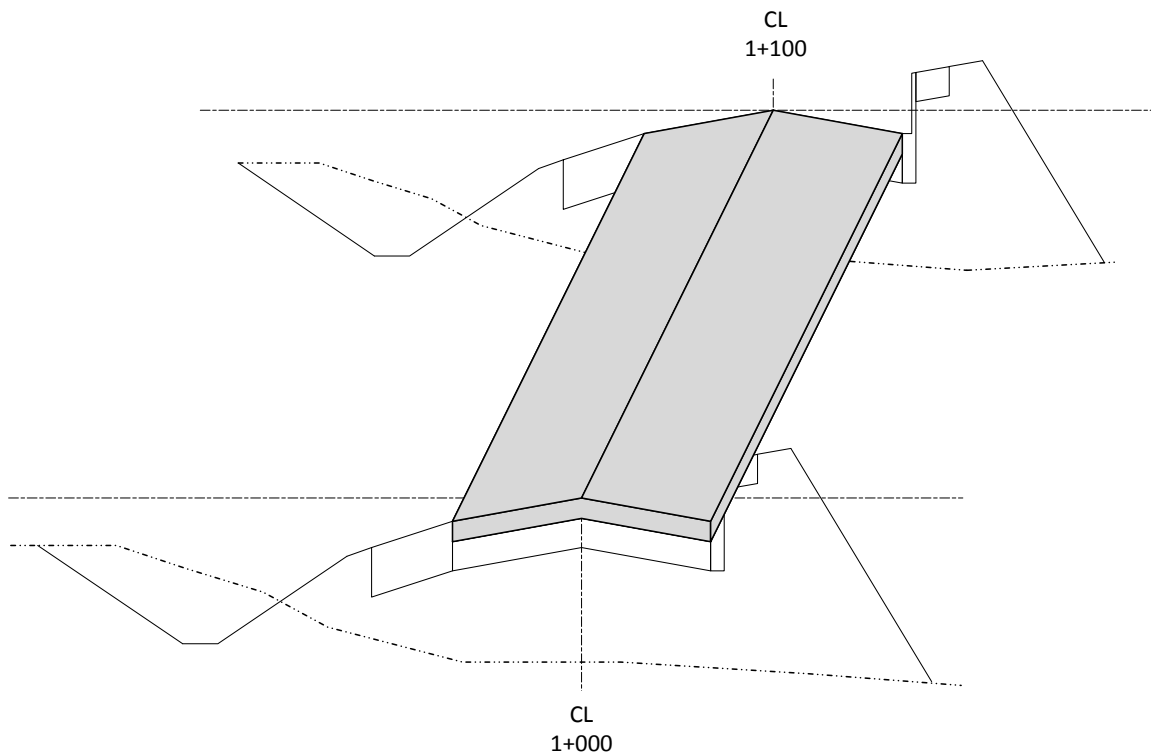

*Figure 6. Pavement as a RoadElement*

A closer look at the pavement RoadElement in Figure 7 shows the point indexes and faces used by the PolyfaceMesh geometric representation. The coordinates for these points are shown in Table 2.

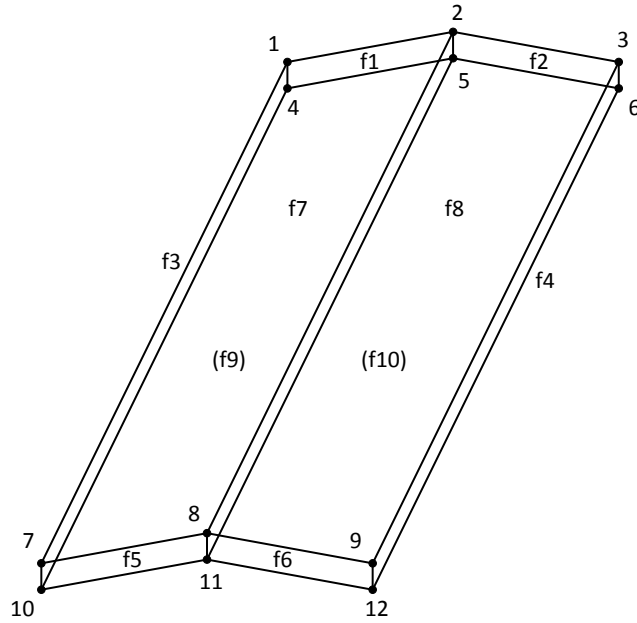

Figure 7. Pavement RoadElement PolyfaceMesh

| Index | X      | Y    | Z      |
|-------|--------|------|--------|
| 1     | -3.650 | 1100 | 48.927 |
| 2     | 0.000  | 1100 | 49.000 |
| 3     | 3.650  | 1100 | 48.927 |
| 4     | -3.650 | 1100 | 48.862 |
| 5     | 0.000  | 1100 | 48.935 |
| 6     | 3.650  | 1100 | 48.862 |
| 7     | -3.650 | 1000 | 49.927 |
| 8     | 0.000  | 1000 | 50.000 |
| 9     | 3.650  | 1000 | 49.927 |
| 10    | -3.650 | 1000 | 49.862 |
| 11    | 0.000  | 1000 | 49.935 |
| 12    | 3.650  | 1000 | 49.862 |

Table 2. PolyfaceMesh indexed Point Coordinates

The GML for the pavement RoadElement would be:

```
<lifr:element>
  <lifr:RoadElement gml:id="re1">
    <gml:description>6.5 cm asphalt top surface course</gml:description>
    <gml:name>top pavement layer</gml:name>
    <spatialRepresentation>
      <geometry>
        <PolyfaceMesh gml:id="mesh1">
          <IndexedPointList>
            <IndexedPoint>
              <index>1</index>
              <coordinates>-3.650 1100 48.927</coordinates>
            </IndexedPoint>
            <IndexedPoint>
              <index>2</index>
              <coordinates>0.000 1100 49.000</coordinates>
            </IndexedPoint>
            <IndexedPoint>
              <index>3</index>
              <coordinates>3.650 1100 48.927</coordinates>
            </IndexedPoint>
            <IndexedPoint>
              <index>4</index>
              <coordinates>-3.650 1100 48.862</coordinates>
            </IndexedPoint>
            <IndexedPoint>
              <index>5</index>
              <coordinates>0.000 1100 48.935</coordinates>
            </IndexedPoint>
            <IndexedPoint>
              <index>6</index>
              <coordinates>3.650 1100 48.862</coordinates>
            </IndexedPoint>
            <IndexedPoint>
              <index>7</index>
              <coordinates>-3.650 1000 49.927</coordinates>
            </IndexedPoint>
            <IndexedPoint>
              <index>8</index>
              <coordinates>0.000 1000 50.000</coordinates>
            </IndexedPoint>
            <IndexedPoint>
              <index>9</index>
              <coordinates>3.650 1000 49.927</coordinates>
            </IndexedPoint>
            <IndexedPoint>
              <index>10</index>
              <coordinates>-3.650 1000 49.862</coordinates>
            </IndexedPoint>
            <IndexedPoint>
              <index>11</index>
              <coordinates>0.000 1000 49.935</coordinates>
            </IndexedPoint>
            <IndexedPoint>
              <index>12</index>
            </IndexedPoint>
          </IndexedPointList>
        </PolyfaceMesh>
      </geometry>
    </spatialRepresentation>
  </lifr:RoadElement>
</lifr:element>
```

```

        <coordinates>3.650 1000 49.862</coordinates>
    </IndexedPoint>
</IndexedPointList>
<SimpleIndexedPolygonList>
    <SimpleIndexedPolygon gml:id="f1">
        <pointIndex>1 2 5 4</pointIndex>
    </SimpleIndexedPolygon>
    <SimpleIndexedPolygon gml:id="f2">
        <pointIndex>2 3 6 5</pointIndex>
    </SimpleIndexedPolygon>
    <SimpleIndexedPolygon gml:id="f3">
        <pointIndex>1 4 10 7</pointIndex>
    </SimpleIndexedPolygon>
    <SimpleIndexedPolygon gml:id="f4">
        <pointIndex>3 9 12 6</pointIndex>
    </SimpleIndexedPolygon>
    <SimpleIndexedPolygon gml:id="f5">
        <pointIndex>8 7 10 11</pointIndex>
    </SimpleIndexedPolygon>
    <SimpleIndexedPolygon gml:id="f6">
        <pointIndex>9 8 11 12</pointIndex>
    </SimpleIndexedPolygon>
    <SimpleIndexedPolygon gml:id="f7">
        <pointIndex>2 1 7 8</pointIndex>
    </SimpleIndexedPolygon>
    <SimpleIndexedPolygon gml:id="f8">
        <pointIndex>3 2 8 9</pointIndex>
    </SimpleIndexedPolygon>
    <SimpleIndexedPolygon gml:id="f9">
        <pointIndex>4 5 11 10</pointIndex>
    </SimpleIndexedPolygon>
    <SimpleIndexedPolygon gml:id="f10">
        <pointIndex>5 6 12 11</pointIndex>
    </SimpleIndexedPolygon>
</SimpleIndexedPolygonList>
</PolyfaceMesh>
</geometry>
</spatialRepresentation>
<linearlyReferencedLocation>
    <LinearFromToLocation>
        <fromPosition>
            <gmlr:PositionExpression gml:id="pe1">
                <gmlr:linearElement xlink:href="le1"></gmlr:linearElement>
                <gmlr:lrm xlink:href="lrm1"/>
                <gmlr:distanceExpression>
                    <gmlr:DistanceExpression gml:id="de1">
                        <gmlr:distanceAlong>1000</gmlr:distanceAlong>
                    </gmlr:DistanceExpression>
                </gmlr:distanceExpression>
            </gmlr:PositionExpression>
        </fromPosition>
        <toPosition>
            <gmlr:PositionExpression gml:id="pe2">
                <gmlr:linearElement xlink:href="le1"></gmlr:linearElement>
                <gmlr:lrm xlink:href="lrm1"/>
                <gmlr:distanceExpression>

```



```

    <gmlr:DistanceExpression gml:id="de2">
      <gmlr:distanceAlong>1100</gmlr:distanceAlong>
    </gmlr:DistanceExpression>
  </gmlr:distanceExpression>
  </gmlr:PositionExpression>
</toPosition>
</LinearFromToLocation>
</linearlyReferencedLocation>
<lifr:roadElementID>
  <lifr:identifier>pavement1</lifr:identifier>
</lifr:roadElementID>
<lifr:roadElementType
  xlink:href="http://example.com/oadElementType#pavementSurfaceCourse"
  xlink:title="Pavement Surface Course"/>
  <lifr:material>asphalt</lifr:material>
</lifr:RoadElement>
</lifr:element>

```

### 7.2.4.3 Surface Representation

Figure 8 shows the top surface of the top pavement layer represented as a single Surface.

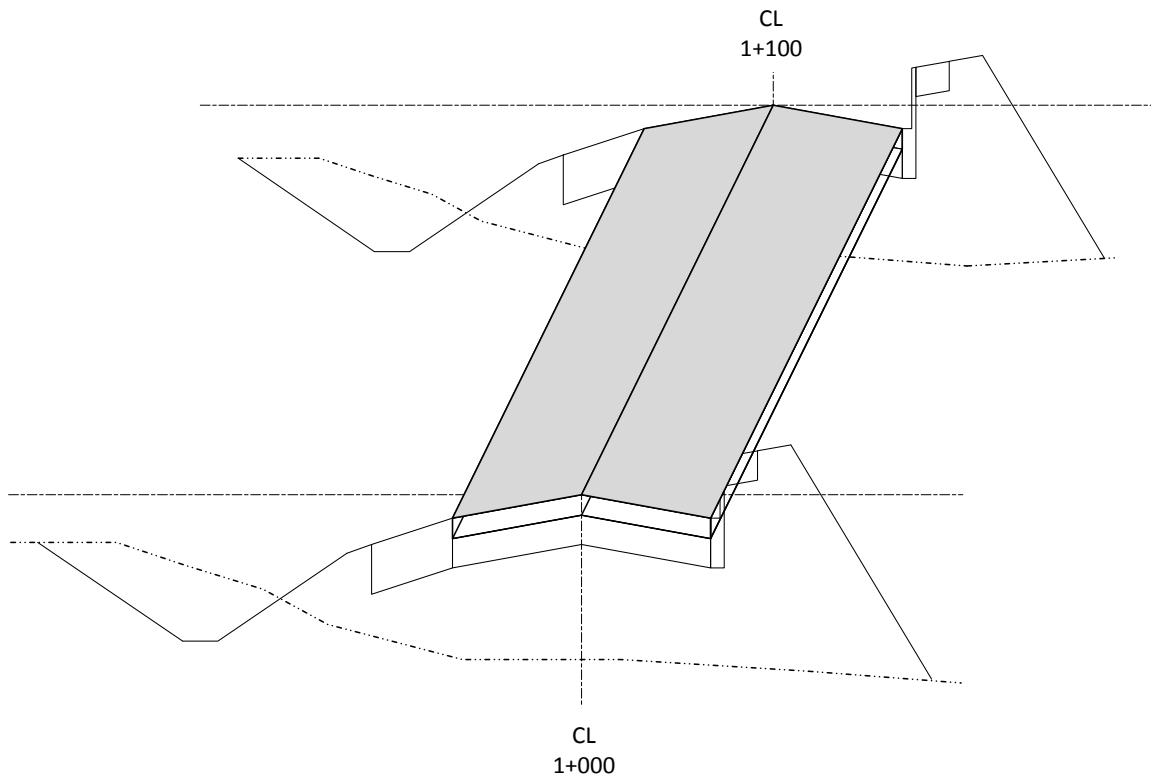

Figure 8. Pavement (Top) Surface Representation

A closer look at the pavement Surface in Figure 9 shows the triangles used in the TIN geometric representation. The coordinates for the triangle vertices are also shown.

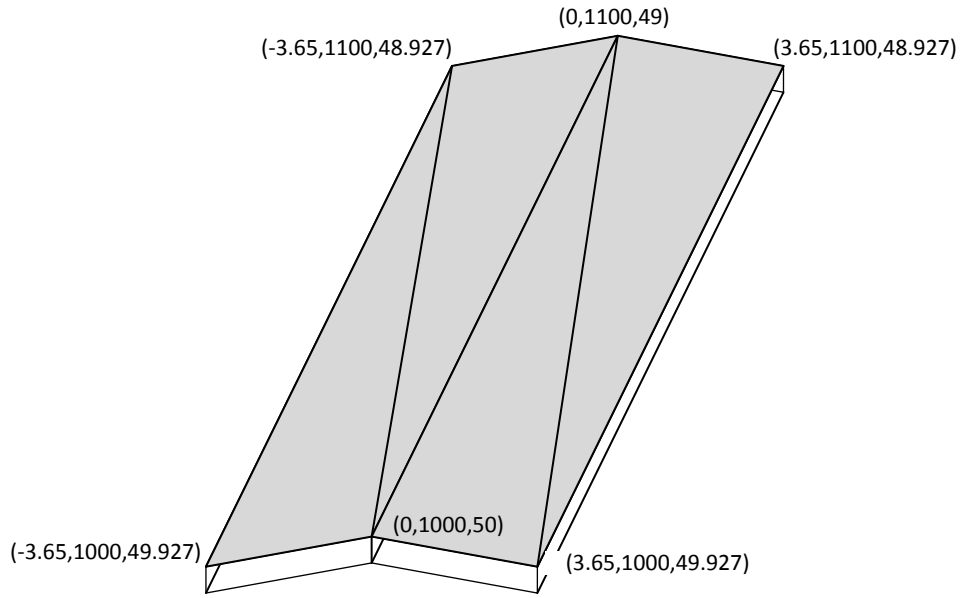

Figure 9. Pavement Triangulated (Top) Surface

The GML for the pavement Surface would be:

```

<lifr:surface>
  <lifr:Surface gml:id="sur1">
    <gml:description>top surface after construction is completed</gml:description>
    <gml:name>top surface</gml:name>
    <lifr:surfaceID>
      <lifr:identifier>surface1</lifr:identifier>
    </lifr:surfaceID>
    <lifr:geometry gml:id="tin1" xsi:type="tin:TINType">
      <gml:trianglePatches>
        <tin:SimpleTrianglePatch>
          <gml:pos>-3.650 1100 48.927</gml:pos>
          <gml:pos>-3.650 1000 49.927</gml:pos>
          <gml:pos>0.000 1000 50.000</gml:pos>
        </tin:SimpleTrianglePatch>
        <tin:SimpleTrianglePatch>
          <gml:pos>0.000 1000 50.000</gml:pos>
          <gml:pos>0.000 1100 49.000</gml:pos>
          <gml:pos>-3.650 1100 48.927</gml:pos>
        </tin:SimpleTrianglePatch>
        <tin:SimpleTrianglePatch>
          <gml:pos>0.000 1100 49.000</gml:pos>
          <gml:pos>0.000 1000 50.000</gml:pos>
          <gml:pos>3.650 1000 49.927</gml:pos>
        </tin:SimpleTrianglePatch>
        <tin:SimpleTrianglePatch>
          <gml:pos>3.650 1000 49.927</gml:pos>
          <gml:pos>3.650 1100 48.927</gml:pos>
          <gml:pos>0.000 1100 49.000</gml:pos>
        </tin:SimpleTrianglePatch>
      </gml:trianglePatches>
    </lifr:geometry>
  </lifr:Surface>
</lifr:surface>

```

</lifr:Surface>  
</lifr:surface>

#### 7.2.4.4 StringLine Representation

Figure 10 shows the top pavement layer represented as a set of three StringLines.

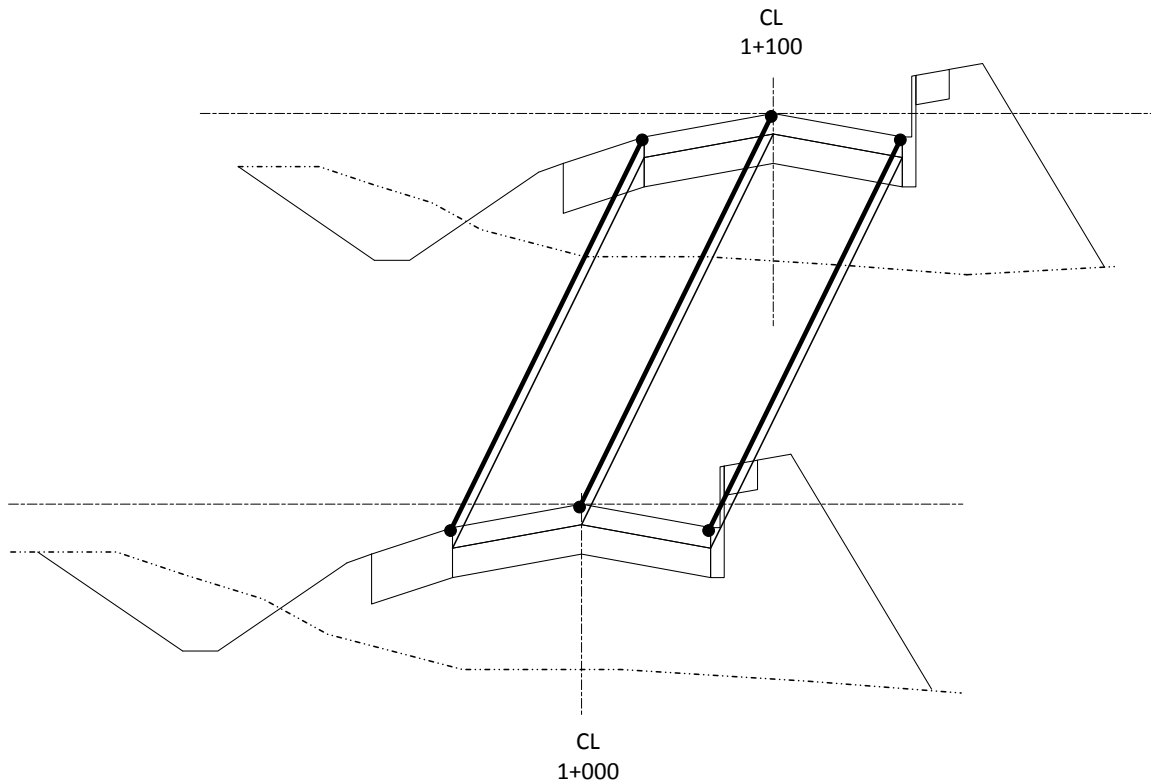

*Figure 10. Pavement StringLine Representation*

A closer look at the pavement in Figure 11 shows the three StringLines included in the StringLine representation: left edge of pavement (LEP), center line of pavement (CLP), and right edge of pavement (REP). These are grouped together into a StringLineSet named “pavement”. The coordinates for the respective StringLine linestring vertices are also shown.

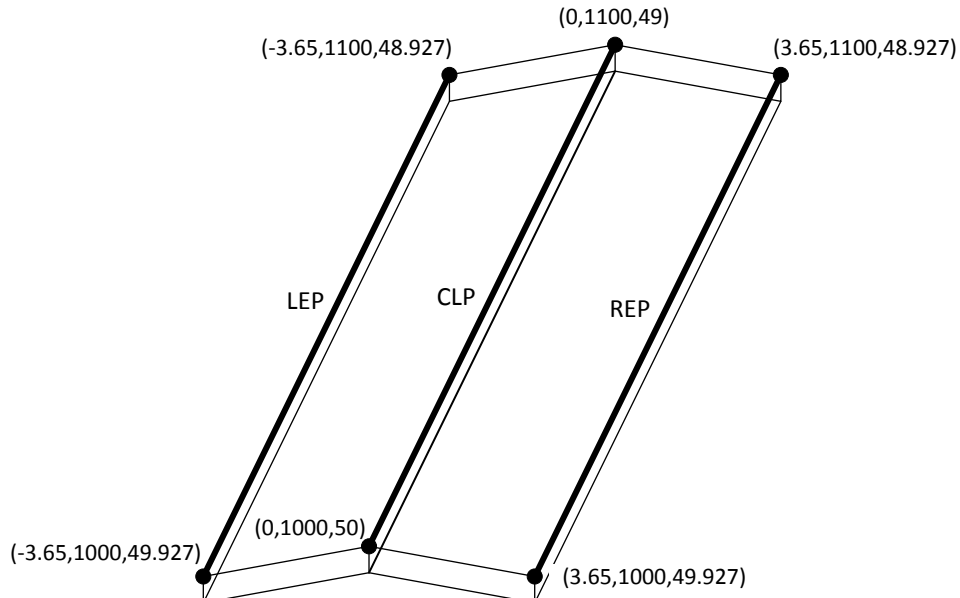

Figure 11. Pavement StringLines

The GML for the pavement StringLineSet would be:

```

<lifr:stringLineSet>
  <lifr:StringLineSet gml:id="sls1">
    <gml:description>string lines delineating the top pavement surface</gml:description>
    <gml:name>top surface pavement</gml:name>
    <lifr:stringLineSetID>
      <lifr:identifier>pavement1</lifr:identifier>
    </lifr:stringLineSetID>
    <lifr:stringLine>
      <lifr:StringLine gml:id="sl1">
        <gml:description>top surface</gml:description>
        <gml:name>left edge pavement</gml:name>
        <lifr:stringLineID>
          <lifr:identifier>LEP</lifr:identifier>
        </lifr:stringLineID>
        <lifr:geometry gml:id="ls1">
          <gml:pos>-3.650 1000 49.927</gml:pos>
          <gml:pos>-3.650 1100 48.927</gml:pos>
        </lifr:geometry>
      </lifr:StringLine>
    </lifr:stringLine>
    <lifr:stringLine>
      <lifr:StringLine gml:id="sl2">
        <gml:description>top surface</gml:description>
        <gml:name>centerline pavement</gml:name>
        <lifr:stringLineID>
          <lifr:identifier>CLP</lifr:identifier>
        </lifr:stringLineID>
        <lifr:geometry gml:id="ls2">
          <gml:pos>0.000 1000 50.000</gml:pos>
          <gml:pos>0.000 1100 49.000</gml:pos>
        </lifr:geometry>
      </lifr:StringLine>
    </lifr:stringLine>
  </lifr:StringLineSet>
</lifr:stringLineSet>

```

```

<lifr:alternativeGeometry xlink:href="ac1"></lifr:alternativeGeometry>
</lifr:StringLine>
</lifr:stringLine>
<lifr:stringLine>
  <lifr:StringLine gml:id="sl3">
    <gml:description>top surface</gml:description>
    <gml:name>right edge pavement</gml:name>
    <lifr:stringLineID>
      <lifr:identifier>REP</lifr:identifier>
    </lifr:stringLineID>
    <lifr:geometry gml:id="ls3">
      <gml:pos>3.650 1000 49.927</gml:pos>
      <gml:pos>3.650 1100 48.927</gml:pos>
    </lifr:geometry>
  </lifr:StringLine>
</lifr:stringLine>
</lifr:StringLineSet>
</lifr:stringLineSet>

```

### 7.3 Requirements Class: RoadCrossSection

| Requirements Class             |  |
|--------------------------------|--|
| <b>/req/road-cross-section</b> |  |
| Target type                    | Conforming application                   |
| Name                           | Road                                     |
| Dependency                     | <b>/req/road</b>                         |
| Requirement                    | <b>/req/road-cross-section/elements</b>  |
| Requirement                    | <b>/req/road-cross-section/alignment</b> |

#### 7.3.1 Implement decisions regarding OGC 15-111r1 UML

The following implement decisions have been made regarding the OGC 15-111r1 Road Cross Sections Requirements Class UML.

1. In order to implement the split between the Road and RoadCrossSection Requirements Classes, it was necessary to create the RoadWithCrossSection subtype of Road which extends Road to include optional CrossSections and CrossSectionSets.
2. IDs have been added for CrossSections and CrossSectionSets.

#### 7.3.2 Specific Requirements for this Requirements Class

|                    |  |
|--------------------|--|
| <b>Requirement</b> | <b>/req/road-cross-section/elements</b>  |
|                    | A conforming application shall support the Road Cross Section XML elements listed in Table 3 in accordance with the GML XSD specified in <a href="http://schemas.opengis.net/infragml/part4/1.0/roadcrosssection.xsd">http://schemas.opengis.net/infragml/part4/1.0/roadcrosssection.xsd</a> . |

An application conforming to this standard shall support the Road XML elements listed below in Table 3 in accordance with the GML XSD specified in <http://schemas.opengis.net/infragml/part4/1.0/road.xsd>. Road XML element names are shown with a XML namespace prefix of “lifrcs”. Corresponding LandInfra UML classes are shown with their LandInfra Requirements Class prefix of “RoadCrossSection”.

| InfraGML XML element         | LandInfra UML Class                             |
|------------------------------|---|
| lifrcs:CrossSection          | RoadCrossSection::CrossSection                  |
| lifrcs:CrossSectionArea      | RoadCrossSection::CrossSectionArea              |
| lifrcs:CrossSectionComponent | RoadCrossSection::CrossSectionComponent         |
| lifrcs:CrossSectionPoint     | RoadCrossSection::CrossSectionPoint             |
| lifrcs:CrossSectionSet       | RoadCrossSection::CrossSectionSet               |
| lifrcs:RoadWithCrossSection  | InfraGML RoadCrossSection::RoadWithCrossSection |

*Table 3. InfraGML Road Cross Section XML elements with corresponding LandInfra UML classes*

The RoadCrossSection Requirements Class provides the fourth way of representing a Road FacilityPart: as 2D views cut perpendicular to the Road centerline. Because this Requirements Class is dependent upon the Road Requirements Class, an application conforming to this RoadCrossSection Requirements Class can include any of the four representations, singularly or in combination. It is up to the application to ensure consistency between multiple representations of the same Road – InfraGML independently supports all four representations, but makes no assurances about consistency between them.

The cross section representation can be specified relative to some linear element, in accordance with OGC Abstract Specification Topic 19, Linear Referencing. If the application supports the InfraGML Alignment Requirements Class, then an Alignment can serve as the linearly locating linear element.

|                    |  |
|--------------------|--|
| <b>Requirement</b> | <p><b>/req/road-cross-section/alignment</b></p> <p>If an application allows the linear element used for locating CrossSections to be an Alignment, then that application shall support the Alignment Requirements Class.</p> |
|--------------------|--|

### 7.3.3 Road with Alignment Example Continued (informative)

The Road with Alignment example in 7.2.4 is extended here to include the cross section representation. Again the focus is only on the top pavement layer. Because this is a different Requirements Class, Road was subtyped as RoadWithCrossSection in order to accommodate the CrossSection and CrossSectionSet representations.

### 7.3.3.1 CrossSection Representation

Figure 12 shows the top pavement layer represented by two CrossSections.

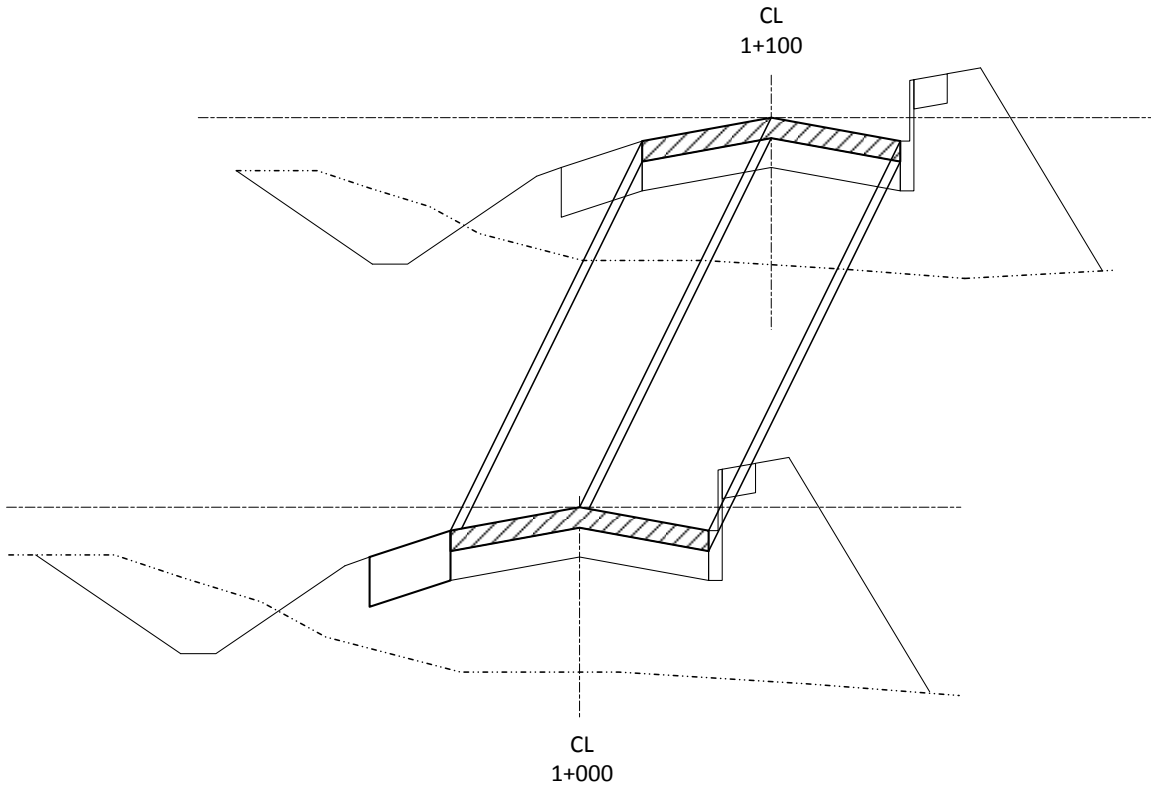

Figure 12. Pavement CrossSection Representation

A closer look at the pavement in Figure 13 shows the pavement CrossSectionComponent contained in the two CrossSections included in the CrossSection representation. The component is the same for both CrossSections. The CrossSections are at Alignment stations 1+000 and 1+100. The two CrossSections are grouped together in a CrossSectionSet called “TwoLaneRoadCrossSections”.

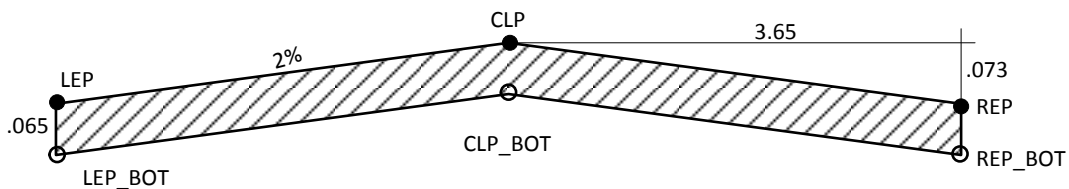

Figure 13. Pavement CrossSectionComponent

CrossSectionPoints are center line of pavement top (CLP), right edge of pavement top (REP), right edge of pavement bottom (REP\_BOT), center line of pavement bottom (CLP\_BOT), and left edge of pavement bottom (LEP\_BOT), and left edge of pavement top (LEP). The coordinates for the CrossSectionPoints are shown in Table 4.

| name    | description                     | horizontal | vertical |
|---------|---------------------------------|------------|----------|
| CLP     | centerline pavement             | 0.000      | 0.000    |
| REP     | right edge of pavement          | 3.650      | -0.073   |
| REP_BOT | right edge of pavement          | 3.650      | -0.138   |
| CLP_BOT | centerline pavement<br>bottom   | 0.000      | -0.065   |
| LEP_BOT | left edge of pavement<br>bottom | -3.650     | -0.138   |
| LEP     | left edge of pavement           | -3.650     | -0.073   |

Table 4. Pavement CrossSectionComponent CrossSectionPoints

The GML for the pavement CrossSectionComponent part of the CrossSection representation would be:

```
<feature>
  <lifrcs:RoadWithCrossSection gml:id="r2">
    <lif:facilityPartID>
      <lif:identifier>Road2</lif:identifier>
    </lif:facilityPartID>
    <lif:type xlink:href="http://example.com/facilityPartType#road"
      xlink:title="Road"/>
    <lif:status xlink:href="http://example.com/status#designed"
      xlink:title="Designed"/>
    <lifr:roadID>
      <lifr:identifier>TwoLaneRoad</lifr:identifier>
    </lifr:roadID>
    <lifr:approximateWidth uom="m">13</lifr:approximateWidth>
    <lifrcs:crossSectionSet>
      <lifrcs:CrossSectionSet gml:id="css1">
        <gml:description>set of cross sections of top surface from 1000 to
          1100</gml:description>
        <gml:name>top surface pavement</gml:name>
        <lifrcs:crossSectionSetID>
          <lifrcs:identifier>TwoLaneRoadCrossSections</lifrcs:identifier>
        </lifrcs:crossSectionSetID>
        <lifrcs:crossSection>
          <lifrcs:CrossSection gml:id="cs1">
            <gml:description>top surface pavement only</gml:description>
            <gml:name>sta 1+000 pavement</gml:name>
            <lifrcs:crossSectionID>
              <lifrcs:identifier>1+000</lifrcs:identifier>
            </lifrcs:crossSectionID>
            <lifrcs:locatedAlong xlink:href="a1"></lifrcs:locatedAlong>
            <lifrcs:distanceAlong>1000</lifrcs:distanceAlong>
            <lifrcs:horizontalDisplacement uom="m">0</lifrcs:horizontalDisplacement>
            <lifrcs:verticalDisplacement uom="m">0</lifrcs:verticalDisplacement>
            <lifrcs:component>
```



```

<lifrcs:CrossSectionComponent gml:id="csc1">
  <gml:description>top surface pavement layer</gml:description>
  <gml:name>pavement</gml:name>
  <lifrcs:crossSectionComponentID>
    <lifrcs:identifier>pavement1</lifrcs:identifier>
  </lifrcs:crossSectionComponentID>
  <lifrcs:material>asphalt</lifrcs:material>
  <lifrcs:isClosed>>true</lifrcs:isClosed>
  <lifrcs:state>proposed</lifrcs:state>
  <lifrcs:point>
    <lifrcs:CrossSectionPoint gml:id="csp1">
      <gml:description>top of finished surface</gml:description>
      <gml:name>center line pavement</gml:name>
      <lifrcs:crossSectionPointID>
        <lifrcs:identifier>CLP</lifrcs:identifier>
      </lifrcs:crossSectionPointID>
      <lifrcs:horizontalOffset uom="m">0</lifrcs:horizontalOffset>
      <lifrcs:verticalOffset uom="m">0</lifrcs:verticalOffset>
    </lifrcs:CrossSectionPoint>
  </lifrcs:point>
  <lifrcs:point>
    <lifrcs:CrossSectionPoint gml:id="csp2">
      <gml:description>top of finished surface</gml:description>
      <gml:name>right edge pavement</gml:name>
      <lifrcs:crossSectionPointID>
        <lifrcs:identifier>REP</lifrcs:identifier>
      </lifrcs:crossSectionPointID>
      <lifrcs:horizontalOffset uom="m">3.65</lifrcs:horizontalOffset>
      <lifrcs:verticalOffset uom="m">-.073</lifrcs:verticalOffset>
    </lifrcs:CrossSectionPoint>
  </lifrcs:point>
  <lifrcs:point>
    <lifrcs:CrossSectionPoint gml:id="csp3">
      <gml:description>bottom of finished surface</gml:description>
      <gml:name>right edge pavement</gml:name>
      <lifrcs:crossSectionPointID>
        <lifrcs:identifier>REP_BOT</lifrcs:identifier>
      </lifrcs:crossSectionPointID>
      <lifrcs:name>right edge pavement bottom</lifrcs:name>
      <lifrcs:horizontalOffset uom="m">3.65</lifrcs:horizontalOffset>
      <lifrcs:verticalOffset uom="m">-.138</lifrcs:verticalOffset>
    </lifrcs:CrossSectionPoint>
  </lifrcs:point>
  <lifrcs:point>
    <lifrcs:CrossSectionPoint gml:id="csp4">
      <gml:description>bottom of finished surface</gml:description>
      <gml:name>center line pavement</gml:name>
      <lifrcs:crossSectionPointID>
        <lifrcs:identifier>CLP_BOT</lifrcs:identifier>
      </lifrcs:crossSectionPointID>
      <lifrcs:horizontalOffset uom="m">0</lifrcs:horizontalOffset>
      <lifrcs:verticalOffset uom="m">-.065</lifrcs:verticalOffset>
    </lifrcs:CrossSectionPoint>
  </lifrcs:point>
  <lifrcs:point>
    <lifrcs:CrossSectionPoint gml:id="csp5">

```

```

    <gml:description>bottom of finished surface</gml:description>
    <gml:name>left edge pavement</gml:name>
    <lifrcs:crossSectionPointID>
      <lifrcs:identifier>LEP_BOT</lifrcs:identifier>
    </lifrcs:crossSectionPointID>
    <lifrcs:horizontalOffset uom="m">-3.65</lifrcs:horizontalOffset>
    <lifrcs:verticalOffset uom="m">-.138</lifrcs:verticalOffset>
  </lifrcs:CrossSectionPoint>
</lifrcs:point>
<lifrcs:point>
  <lifrcs:CrossSectionPoint gml:id="csp6">
    <gml:description>top of finished surface</gml:description>
    <gml:name>left edge pavement</gml:name>
    <lifrcs:crossSectionPointID>
      <lifrcs:identifier>LEP</lifrcs:identifier>
    </lifrcs:crossSectionPointID>
    <lifrcs:horizontalOffset uom="m">-3.65</lifrcs:horizontalOffset>
    <lifrcs:verticalOffset uom="m">-.073</lifrcs:verticalOffset>
  </lifrcs:CrossSectionPoint>
</lifrcs:point>
</lifrcs:CrossSectionComponent>
</lifrcs:component>
</lifrcs:CrossSection>
</lifrcs:crossSection>
<lifrcs:crossSection>
  <lifrcs:CrossSection gml:id="cs2">
    <gml:description>top surface pavement only</gml:description>
    <gml:name>sta 1+100 pavement</gml:name>
    <lifrcs:crossSectionID>
      <lifrcs:identifier>1+100</lifrcs:identifier>
    </lifrcs:crossSectionID>
    <lifrcs:locatedAlong xlink:href="a1"></lifrcs:locatedAlong>
    <lifrcs:distanceAlong>1100</lifrcs:distanceAlong>
    <lifrcs:horizontalDisplacement uom="m">0</lifrcs:horizontalDisplacement>
    <lifrcs:verticalDisplacement uom="m">0</lifrcs:verticalDisplacement>
    <lifrcs:component xlink:href="csc1"/>
  </lifrcs:CrossSection>
</lifrcs:crossSection>
</lifrcs:CrossSectionSet>
</lifrcs:crossSectionSet>
</lifrcs:RoadWithCrossSection>
</feature>

```

## 8. Media Types for any data encoding(s)

Data for all Parts of the InfraGML encoding standard is encoded in GML-conformant XML documents. The standard MIME-type and sub-type for GML data should be used to indicate the encoding in internet exchange, as specified in MIME Media Types for GML, namely ‘application/gml+xml’.

## Annex A: Conformance Class Abstract Test Suite (Normative)

### A.1 Conformance class: Road

|                   |   |   |
|-------------------|---|---|
| <b>/conf/road</b> |   |   |
| Requirements      | <a href="#">/req/road</a>                                 |   |
| Dependency        | <a href="#">/conf/land-feature</a> (from InfraGML Part 1) |   |
| Dependency        | <a href="#">/conf/facility</a> (from InfraGML Part 2)     |   |
| Test              | <b>/conf/road/elements</b>                                |   |
|                   | Requirement   | <a href="#">/req/road/elements</a>  |
|                   | Test purpose  | Verify that the conforming application supports the Road XML elements listed in Table 1 in accordance with the GML XSD specified in <a href="http://schemas.opengis.net/infragml/part4/1.0/road.xsd">http://schemas.opengis.net/infragml/part4/1.0/road.xsd</a> . |
|                   | Test method   | Inspect the GML output to verify the above requirement.   |
|                   | Test type   | Capability  |
| Test              | <b>/conf/road/alignment</b>                               |   |
|                   | Requirement   | <a href="#">/req/road/alignment</a>   |
|                   | Test purpose  | Verify that if the application allows the linear element used for locating RoadElements to be an Alignment, or if it allows the StringLine curve geometry to be of type AlignmentCurve, then that application shall support the Alignment Requirements Class.     |
|                   | Test method   | Inspect the application to verify the above requirement is satisfied.   |
|                   | Test type   | Capability  |

### A.2 Conformance class: RoadCrossSection

|                                 |   |   |
|---------------------------------|---|---|
| <b>/conf/road-cross-section</b> |   |   |
| Requirements                    | <a href="#">/req/road-cross-section</a>   |   |
| Dependency                      | <a href="#">/conf/road</a>                |   |
| Test                            | <b>/conf/road-cross-section/elements</b>  |   |
|                                 | Requirement                               | <a href="#">/req/road-cross-section/elements</a>  |
|                                 | Test purpose                              | Verify that the conforming application supports the Road Cross Section XML elements listed in Table 3 in accordance with the GML XSD specified in <a href="http://schemas.opengis.net/infragml/part4/1.0/roadcrosssection.xsd">http://schemas.opengis.net/infragml/part4/1.0/roadcrosssection.xsd</a> . |
|                                 | Test method                               | Inspect the GML output to verify the above requirement.   |
|                                 | Test type                                 | Capability  |
| Test                            | <b>/conf/road-cross-section/alignment</b> |   |
|                                 | Requirement                               | <a href="#">/req/road-cross-section/alignment</a>   |

|  |              |  |
|--|--------------|--|
|  | Test purpose | Verify that if the application allows the linear element used for locating CrossSections to be an Alignment, then that application shall support the Alignment Requirements Class. |
|  | Test method  | Inspect the application to verify the above requirement is satisfied.  |
|  | Test type    | Capability   |

## Annex B: Sample XML (Informative)

The following XML instance documents attempt to demonstrate the use of most all of the elements supported by the specified Requirements Class(es), including all optional properties. All values are exemplary only and not intended to represent actual real world instance values. Not all xlink references are resolvable within this document.

### B.1 Complete Road (less Cross Sections) XML

Example from Part4Road0410.xsd

```
<?xml version="1.0" encoding="UTF-8"?>
<LandInfraDataset
xmlns="http://www.opengis.net/infragml/core/1.0"
xmlns:gml="http://www.opengis.net/gml/3.2"
gml:id="ds4a"
xmlns:xlink="http://www.w3.org/1999/xlink"
xmlns:li="http://www.opengis.net/infragml/core/1.0"
xmlns:lilf="http://www.opengis.net/infragml/landfeature/1.0"
xmlns:lif="http://www.opengis.net/infragml/facility/1.0"
xmlns:lia="http://www.opengis.net/infragml/alignment/1.0"
xmlns:lifr="http://www.opengis.net/infragml/road/1.0"
xmlns:gmlr="http://www.opengis.net/gml/3.3/lr"
xmlns:gmlro="http://www.opengis.net/gml/3.3/lro"
xmlns:tin="http://www.opengis.net/gml/3.3/tin"
xmlns:xsi="http://www.w3.org/2001/XMLSchema-instance"
xsi:schemaLocation="http://www.opengis.net/infragml/road/1.0 Part4Road0410.xsd">
  <datasetID>
    <ID>
      <identifier>DS4a</identifier>
      <scope>OGC LandInfraSWG</scope>
    </ID>
  </datasetID>
  <name>Sample Part4a Dataset</name>
  <description>LandInfra dataset to test all possible content for Part4 Road (without Cross
    Sections)
  </description>
  <dateTime>2016-12-02T10:00:00</dateTime>
  <datasetVersion>1.0</datasetVersion>
  <application>manual</application>
  <author>Paul Scarponcini, Bentley Systems, Inc.</author>
  <infraVersion>1.0</infraVersion>
  <language>English</language>
  <defaultCRS xlink:href="crs1"/>
  <feature>
    <lia:Alignment gml:id="a1">
      <lia:alignmentID>
        <lia:ID>
          <identifier>Alignment1</identifier>
        </lia:ID>
      </lia:alignmentID>
      <lia:geometry>
        <lia:AlignmentCurve gml:id="ac1">
          <lia:horizontal>
```

```

<lia:Alignment2DHorizontal gml:id="ah1">
  <lia:location>road centerline</lia:location>
  <lia:description></lia:description>
  <lia:state>proposed</lia:state>
  <lia:segment>
    <lia:Alignment2DHorSegment>
      <lia:tangentialContinuity>true</lia:tangentialContinuity>
      <lia:geometry>
        <lia:LineSegment>
          <gml:pos>0 1000</gml:pos>
          <gml:pos>0 1100</gml:pos>
        </lia:LineSegment>
      </lia:geometry>
    </lia:Alignment2DHorSegment>
  </lia:segment>
</lia:Alignment2DHorizontal>
</lia:horizontal>
<lia:vertical>
  <lia:Alignment2DVertical gml:id="av1">
    <lia:location>road centerline</lia:location>
    <lia:description></lia:description>
    <lia:state>proposed</lia:state>
    <lia:segments>
      <lia:Alignment2DVertSegment>
        <lia:tangentialContinuity>true</lia:tangentialContinuity>
        <lia:startDistAlong>
          <gmlr:DistanceExpression gml:id="sda1">
            <gmlr:distanceAlong>1000</gmlr:distanceAlong>
          </gmlr:DistanceExpression>
        </lia:startDistAlong>
        <lia:startHeight uom="m">50</lia:startHeight>
        <lia:startGradient>-1.0</lia:startGradient>
        <lia:horizontalLength uom="m">100</lia:horizontalLength>
      </lia:Alignment2DVertSegment>
    </lia:segments>
    <lia:measuredAlong xlink:href="ah1"></lia:measuredAlong>
  </lia:Alignment2DVertical>
</lia:vertical>
</lia:AlignmentCurve>
</lia:geometry>
</lia:Alignment>
</feature>
<linearElement>
  <LinearElement gml:id="le1">
    <gmlr:feature xlink:href="a1" xlink:title="alignment a1">
      </gmlr:feature>
      <gmlr:defaultLRM xlink:href="lrm1"/>
      <gmlr:measure uom="m">100</gmlr:measure>
    </LinearElement>
  </linearElement>
<feature>
  <lif:Facility gml:id="fac1">
    <lif:facilityID>
      <lif:ID>
        <identifier>101</identifier>
      </lif:ID>
    </lif:facilityID>
  </lif:Facility>
</feature>

```

```

</lif:facilityID>
<lif:type>campus</lif:type>
<lif:status xlink:href="http://example.com/status#planned"
  xlink:title="Planned"/>
<lif:footprint xlink:href="poly1" xlink:title="Polygon">
</lif:footprint>
<lif:part xlink:href="r1"></lif:part>
</lif:Facility>
</feature>
<feature>
<lifr:Road gml:id="r1">
  <lif:facilityPartID>
    <lif:ID>
      <identifier>Road1</identifier>
    </lif:ID>
  </lif:facilityPartID>
  <lif:type xlink:href="http://example.com/facilityPartType#road"
    xlink:title="Road"/>
  <lif:status xlink:href="http://example.com/status#designed"
    xlink:title="Designed"/>
  <lifr:roadID>
    <lifr:ID>
      <identifier>TwoLaneRoad</identifier>
    </lifr:ID>
  </lifr:roadID>
  <lifr:approximateWidth uom="m">13</lifr:approximateWidth>
  <lifr:element>
    <lifr:RoadElement gml:id="re1">
      <gml:description>6.5 cm asphalt top surface course</gml:description>
      <gml:name>top pavement layer</gml:name>
      <spatialRepresentation>
        <SpatialRepresentation>
          <geometry>
            <PolyfaceMesh gml:id="mesh1">
              <indexedPointList>
                <IndexedPoint>
                  <index>1</index>
                  <coordinates>-3.650 1100 48.927</coordinates>
                </IndexedPoint>
                <IndexedPoint>
                  <index>2</index>
                  <coordinates>0.000 1100 49.000</coordinates>
                </IndexedPoint>
                <IndexedPoint>
                  <index>3</index>
                  <coordinates>3.650 1100 48.927</coordinates>
                </IndexedPoint>
                <IndexedPoint>
                  <index>4</index>
                  <coordinates>-3.650 1100 48.862</coordinates>
                </IndexedPoint>
                <IndexedPoint>
                  <index>5</index>
                  <coordinates>0.000 1100 48.935</coordinates>
                </IndexedPoint>
                <IndexedPoint>

```

```

    <index>6</index>
    <coordinates>3.650 1100 48.862</coordinates>
  </IndexedPoint>
  <IndexedPoint>
    <index>7</index>
    <coordinates>-3.650 1000 49.927</coordinates>
  </IndexedPoint>
  <IndexedPoint>
    <index>8</index>
    <coordinates>0.000 1000 50.000</coordinates>
  </IndexedPoint>
  <IndexedPoint>
    <index>9</index>
    <coordinates>3.650 1000 49.927</coordinates>
  </IndexedPoint>
  <IndexedPoint>
    <index>10</index>
    <coordinates>-3.650 1000 49.862</coordinates>
  </IndexedPoint>
  <IndexedPoint>
    <index>11</index>
    <coordinates>0.000 1000 49.935</coordinates>
  </IndexedPoint>
  <IndexedPoint>
    <index>12</index>
    <coordinates>3.650 1000 49.862</coordinates>
  </IndexedPoint>
</indexedPointList>
<simpleIndexedPolygonList>
  <SimpleIndexedPolygon gml:id="f1">
    <pointIndex>1 2 5 4</pointIndex>
  </SimpleIndexedPolygon>
  <SimpleIndexedPolygon gml:id="f2">
    <pointIndex>2 3 6 5</pointIndex>
  </SimpleIndexedPolygon>
  <SimpleIndexedPolygon gml:id="f3">
    <pointIndex>1 4 10 7</pointIndex>
  </SimpleIndexedPolygon>
  <SimpleIndexedPolygon gml:id="f4">
    <pointIndex>3 9 12 6</pointIndex>
  </SimpleIndexedPolygon>
  <SimpleIndexedPolygon gml:id="f5">
    <pointIndex>8 7 10 11</pointIndex>
  </SimpleIndexedPolygon>
  <SimpleIndexedPolygon gml:id="f6">
    <pointIndex>9 8 11 12</pointIndex>
  </SimpleIndexedPolygon>
  <SimpleIndexedPolygon gml:id="f7">
    <pointIndex>2 1 7 8</pointIndex>
  </SimpleIndexedPolygon>
  <SimpleIndexedPolygon gml:id="f8">
    <pointIndex>3 2 8 9</pointIndex>
  </SimpleIndexedPolygon>
  <SimpleIndexedPolygon gml:id="f9">
    <pointIndex>4 5 11 10</pointIndex>
  </SimpleIndexedPolygon>

```



```

        <SimpleIndexedPolygon gml:id="f10">
          <pointIndex>5 6 12 11</pointIndex>
        </SimpleIndexedPolygon>
      </simpleIndexedPolygonList>
    </PolyfaceMesh>
  </geometry>
</SpatialRepresentation>
</spatialRepresentation>
<linearlyReferencedLocation>
  <LinearlyReferencedLocation>
    <linearFromToLocation>
      <LinearFromToLocation>
        <fromPosition>
          <gmlr:PositionExpression gml:id="pe1">
            <gmlr:linearElement xlink:href="le1"></gmlr:linearElement>
            <gmlr:lrn xlink:href="lrm1"/>
            <gmlr:distanceExpression>
              <gmlr:DistanceExpression gml:id="de1">
                <gmlr:distanceAlong>1000</gmlr:distanceAlong>
              </gmlr:DistanceExpression>
            </gmlr:distanceExpression>
          </gmlr:PositionExpression>
        </fromPosition>
        <toPosition>
          <gmlr:PositionExpression gml:id="pe2">
            <gmlr:linearElement xlink:href="le1"></gmlr:linearElement>
            <gmlr:lrn xlink:href="lrm1"/>
            <gmlr:distanceExpression>
              <gmlr:DistanceExpression gml:id="de2">
                <gmlr:distanceAlong>1100</gmlr:distanceAlong>
              </gmlr:DistanceExpression>
            </gmlr:distanceExpression>
          </gmlr:PositionExpression>
        </toPosition>
      </LinearFromToLocation>
    </linearFromToLocation>
  </LinearlyReferencedLocation>
</linearlyReferencedLocation>
<lifr:roadElementID>
  <lifr:ID>
    <identifier>pavement1</identifier>
  </lifr:ID>
</lifr:roadElementID>
<lifr:roadElementType
  xlink:href="http://example.com/oadElementType#pavementSurfaceCourse"
  xlink:title="Pavement Surface Course"/>
  <lifr:material>asphalt</lifr:material>
</lifr:RoadElement>
</lifr:element>
<lifr:surface>
  <lifr:Surface gml:id="sur1">
    <gml:description>top surface after construction is completed</gml:description>
    <gml:name>top surface</gml:name>
    <lifr:surfaceID>
      <lifr:ID>
        <identifier>surface1</identifier>

```

```

</lifr:ID>
</lifr:surfaceID>
<lifr:geometry>
  <lifr:TIN gml:id="tin1">
    <gml:patches>
      <tin:SimpleTrianglePatch>
        <gml:pos>-3.650 1100 48.927</gml:pos>
        <gml:pos>-3.650 1000 49.927</gml:pos>
        <gml:pos>0.000 1000 50.000</gml:pos>
      </tin:SimpleTrianglePatch>
      <tin:SimpleTrianglePatch>
        <gml:pos>0.000 1000 50.000</gml:pos>
        <gml:pos>0.000 1100 49.000</gml:pos>
        <gml:pos>-3.650 1100 48.927</gml:pos>
      </tin:SimpleTrianglePatch>
      <tin:SimpleTrianglePatch>
        <gml:pos>0.000 1100 49.000</gml:pos>
        <gml:pos>0.000 1000 50.000</gml:pos>
        <gml:pos>3.650 1000 49.927</gml:pos>
      </tin:SimpleTrianglePatch>
      <tin:SimpleTrianglePatch>
        <gml:pos>3.650 1000 49.927</gml:pos>
        <gml:pos>3.650 1100 48.927</gml:pos>
        <gml:pos>0.000 1100 49.000</gml:pos>
      </tin:SimpleTrianglePatch>
    </gml:patches>
  </lifr:TIN>
</lifr:geometry>
</lifr:Surface>
</lifr:surface>
<lifr:stringLineSet>
  <lifr:StringLineSet gml:id="sls1">
    <gml:description>string lines delineating the top pavement surface</gml:description>
    <gml:name>top surface pavement</gml:name>
    <lifr:stringLineSetID>
      <lifr:ID>
        <identifier>pavement1</identifier>
      </lifr:ID>
    </lifr:stringLineSetID>
    <lifr:stringLine>
      <lifr:StringLine gml:id="sl1">
        <gml:description>top surface</gml:description>
        <gml:name>left edge pavement</gml:name>
        <lifr:stringLineID>
          <lifr:ID>
            <identifier>LEP</identifier>
          </lifr:ID>
        </lifr:stringLineID>
        <lifr:geometry>
          <lifr:LineString gml:id="ls1">
            <gml:pos>-3.650 1000 49.927</gml:pos>
            <gml:pos>-3.650 1100 48.927</gml:pos>
          </lifr:LineString>
        </lifr:geometry>
      </lifr:StringLine>
    </lifr:stringLine>
  </lifr:stringLineSet>

```

```

<lifr:stringLine>
  <lifr:StringLine gml:id="sl2">
    <gml:description>top surface</gml:description>
    <gml:name>centerline pavement</gml:name>
    <lifr:stringLineID>
      <lifr:ID>
        <identifier>CLP</identifier>
      </lifr:ID>
    </lifr:stringLineID>
    <lifr:geometry>
      <lifr:LineString gml:id="ls2">
        <gml:pos>0.000 1000 50.000</gml:pos>
        <gml:pos>0.000 1100 49.000</gml:pos>
      </lifr:LineString>
    </lifr:geometry>
    <lifr:alternativeGeometry xlink:href="ac1"/>
  </lifr:StringLine>
</lifr:stringLine>
<lifr:stringLine>
  <lifr:StringLine gml:id="sl3">
    <gml:description>top surface</gml:description>
    <gml:name>right edge pavement</gml:name>
    <lifr:stringLineID>
      <lifr:ID>
        <identifier>REP</identifier>
      </lifr:ID>
    </lifr:stringLineID>
    <lifr:geometry>
      <lifr:LineString gml:id="ls3">
        <gml:pos>3.650 1000 49.927</gml:pos>
        <gml:pos>3.650 1100 48.927</gml:pos>
      </lifr:LineString>
    </lifr:geometry>
  </lifr:StringLine>
</lifr:stringLine>
</lifr:StringLineSet>
</lifr:stringLineSet>
</lifr:Road>
</feature>
</LandInfraDataset>

```

## B. 2 Complete Road Cross Section XML

Example from Part4RoadCrossSection0410.xsd

```

<?xml version="1.0" encoding="UTF-8"?>
<LandInfraDataset
  xmlns="http://www.opengis.net/infragml/core/1.0"
  xmlns:gml="http://www.opengis.net/gml/3.2"
  gml:id="ds4b"
  xmlns:xlink="http://www.w3.org/1999/xlink"
  xmlns:li="http://www.opengis.net/infragml/core/1.0"
  xmlns:lilf="http://www.opengis.net/infragml/landfeature/1.0"
  xmlns:lif="http://www.opengis.net/infragml/facility/1.0"
  xmlns:lia="http://www.opengis.net/infragml/alignment/1.0"

```

```

xmlns:lifr="http://www.opengis.net/infragml/road/1.0"
xmlns:lifrcs="http://www.opengis.net/infragml/roadcrosssection/1.0"
xmlns:gmlr="http://www.opengis.net/gml/3.3/lr"
xmlns:gmlro="http://www.opengis.net/gml/3.3/lro"
xmlns:tin="http://www.opengis.net/gml/3.3/tin"
xmlns:xsi="http://www.w3.org/2001/XMLSchema-instance"
xsi:schemaLocation="http://www.opengis.net/infragml/roadcrosssection/1.0
Part4RoadCrossSection0410.xsd">
  <datasetID>
    <ID>
      <identifier>DS4b</identifier>
      <scope>OGC LandInfraSWG</scope>
    </ID>
  </datasetID>
  <name>Sample Part4b Dataset</name>
  <description>LandInfra dataset to test all possible content for Part4 Road Cross Sections
</description>
  <dateTime>2016-12-02T10:00:00</dateTime>
  <datasetVersion>1.0</datasetVersion>
  <application>>manual</application>
  <author>Paul Scarponcini, Bentley Systems, Inc.</author>
  <infraVersion>1.0</infraVersion>
  <language>English</language>
  <defaultCRS xlink:href="crs1"/>
  <feature>
    <lifrcs:RoadWithCrossSection gml:id="r2">
      <lif:facilityPartID>
        <lif:ID>
          <identifier>Road2</identifier>
        </lif:ID>
      </lif:facilityPartID>
      <lif:type xlink:href="http://example.com/facilityPartType#road"
xlink:title="Road"/>
      <lif:status xlink:href="http://example.com/status#designed"
xlink:title="Designed"/>
      <lifr:roadID>
        <lifr:ID>
          <identifier>TwoLaneRoad</identifier>
        </lifr:ID>
      </lifr:roadID>
      <lifr:approximateWidth uom="m">13</lifr:approximateWidth>
      <lifrcs:crossSectionSet>
        <lifrcs:CrossSectionSet gml:id="css1">
          <gml:description>set of cross sections of top surface from 1000 to
1100</gml:description>
          <gml:name>top surface pavement</gml:name>
          <lifrcs:crossSectionSetID>
            <lifrcs:ID>
              <identifier>TwoLaneRoadCrossSections</identifier>
            </lifrcs:ID>
          </lifrcs:crossSectionSetID>
          <lifrcs:crossSection>
            <lifrcs:CrossSection gml:id="cs1">
              <gml:description>top surface pavement only</gml:description>
              <gml:name>sta 1+000 pavement</gml:name>
              <lifrcs:crossSectionID>

```

```

<lifrcs:ID>
  <identifier>1+000</identifier>
</lifrcs:ID>
</lifrcs:crossSectionID>
<lifrcs:locatedAlong xlink:href="a1"></lifrcs:locatedAlong>
<lifrcs:distanceAlong>
  <gmlr:DistanceExpression gml:id="de1">
    <gmlr:distanceAlong>1000</gmlr:distanceAlong>
  </gmlr:DistanceExpression>
</lifrcs:distanceAlong>
<lifrcs:horizontalDisplacement uom="m">0</lifrcs:horizontalDisplacement>
<lifrcs:verticalDisplacement uom="m">0</lifrcs:verticalDisplacement>
<lifrcs:component>
  <lifrcs:CrossSectionComponent gml:id="csc1">
    <gml:description>top surface pavement layer</gml:description>
    <gml:name>pavement</gml:name>
    <lifrcs:crossSectionComponentID>
      <lifrcs:ID>
        <identifier>pavement1</identifier>
      </lifrcs:ID>
    </lifrcs:crossSectionComponentID>
    <lifrcs:material>asphalt</lifrcs:material>
    <lifrcs:isClosed>true</lifrcs:isClosed>
    <lifrcs:state>proposed</lifrcs:state>
    <lifrcs:point>
      <lifrcs:CrossSectionPoint gml:id="csp1">
        <gml:description>top of finished surface</gml:description>
        <gml:name>center line pavement</gml:name>
        <lifrcs:crossSectionPointID>
          <lifrcs:ID>
            <identifier>CLP</identifier>
          </lifrcs:ID>
        </lifrcs:crossSectionPointID>
        <lifrcs:horizontalOffset uom="m">0</lifrcs:horizontalOffset>
        <lifrcs:verticalOffset uom="m">0</lifrcs:verticalOffset>
      </lifrcs:CrossSectionPoint>
    </lifrcs:point>
    <lifrcs:point>
      <lifrcs:CrossSectionPoint gml:id="csp2">
        <gml:description>top of finished surface</gml:description>
        <gml:name>right edge pavement</gml:name>
        <lifrcs:crossSectionPointID>
          <lifrcs:ID>
            <identifier>REP</identifier>
          </lifrcs:ID>
        </lifrcs:crossSectionPointID>
        <lifrcs:horizontalOffset uom="m">3.65</lifrcs:horizontalOffset>
        <lifrcs:verticalOffset uom="m">-.073</lifrcs:verticalOffset>
      </lifrcs:CrossSectionPoint>
    </lifrcs:point>
    <lifrcs:point>
      <lifrcs:CrossSectionPoint gml:id="csp3">
        <gml:description>bottom of finished surface</gml:description>
        <gml:name>right edge pavement</gml:name>
        <lifrcs:crossSectionPointID>
          <lifrcs:ID>

```

```

        <identifier>REP_BOT</identifier>
      </lifrcs:ID>
    </lifrcs:crossSectionPointID>
    <lifrcs:horizontalOffset uom="m">3.65</lifrcs:horizontalOffset>
    <lifrcs:verticalOffset uom="m">-.138</lifrcs:verticalOffset>
  </lifrcs:CrossSectionPoint>
</lifrcs:point>
<lifrcs:point>
  <lifrcs:CrossSectionPoint gml:id="csp4">
    <gml:description>bottom of finished surface</gml:description>
    <gml:name>center line pavement</gml:name>
    <lifrcs:crossSectionPointID>
      <lifrcs:ID>
        <identifier>CLP_BOT</identifier>
      </lifrcs:ID>
    </lifrcs:crossSectionPointID>
    <lifrcs:horizontalOffset uom="m">0</lifrcs:horizontalOffset>
    <lifrcs:verticalOffset uom="m">-.065</lifrcs:verticalOffset>
  </lifrcs:CrossSectionPoint>
</lifrcs:point>
<lifrcs:point>
  <lifrcs:CrossSectionPoint gml:id="csp5">
    <gml:description>bottom of finished surface</gml:description>
    <gml:name>left edge pavement</gml:name>
    <lifrcs:crossSectionPointID>
      <lifrcs:ID>
        <identifier>LEP_BOT</identifier>
      </lifrcs:ID>
    </lifrcs:crossSectionPointID>
    <lifrcs:horizontalOffset uom="m">-3.65</lifrcs:horizontalOffset>
    <lifrcs:verticalOffset uom="m">-.138</lifrcs:verticalOffset>
  </lifrcs:CrossSectionPoint>
</lifrcs:point>
<lifrcs:point>
  <lifrcs:CrossSectionPoint gml:id="csp6">
    <gml:description>top of finished surface</gml:description>
    <gml:name>left edge pavement</gml:name>
    <lifrcs:crossSectionPointID>
      <lifrcs:ID>
        <identifier>LEP</identifier>
      </lifrcs:ID>
    </lifrcs:crossSectionPointID>
    <lifrcs:horizontalOffset uom="m">-3.65</lifrcs:horizontalOffset>
    <lifrcs:verticalOffset uom="m">-.073</lifrcs:verticalOffset>
  </lifrcs:CrossSectionPoint>
</lifrcs:point>
</lifrcs:CrossSectionComponent>
</lifrcs:component>
</lifrcs:CrossSection>
</lifrcs:crossSection>
<lifrcs:crossSection>
  <lifrcs:CrossSection gml:id="cs2">
    <gml:description>top surface pavement only</gml:description>
    <gml:name>sta 1+100 pavement</gml:name>
    <lifrcs:crossSectionID>
      <lifrcs:ID>

```

```

        <identifier>1+100</identifier>
    </lifrcs:ID>
</lifrcs:crossSectionID>
<lifrcs:locatedAlong xlink:href="a1"></lifrcs:locatedAlong>
<lifrcs:distanceAlong>
    <gmlr:DistanceExpression gml:id="de2">
        <gmlr:distanceAlong>1100</gmlr:distanceAlong>
    </gmlr:DistanceExpression>
</lifrcs:distanceAlong>
<lifrcs:horizontalDisplacement uom="m">0</lifrcs:horizontalDisplacement>
<lifrcs:verticalDisplacement uom="m">0</lifrcs:verticalDisplacement>
<lifrcs:component xlink:href="csc1"/>
</lifrcs:CrossSection>
</lifrcs:crossSection>
</lifrcs:CrossSectionSet>
</lifrcs:crossSectionSet>
</lifrcs:RoadWithCrossSection>
</feature>
</LandInfraDataset>

```

## Annex C: Revision history

| Date     | Release | Author           | Paragraph modified | Description                  |
|----------|---------|------------------|--------------------|------------------------------|
| 20170307 | 104r1   | Scarponcini      | Figure 2           | Dependency changes in Part 6 |
| 20170410 | 104r2   | Paul Scarponcini | Annex B            | Fixed GML striping           |
|          |         |                  |                    |                              |
|          |         |                  |                    |                              |
|          |         |                  |                    |                              |



## **Annex D: Bibliography**

- [1] OGC: OGC 08-131r3 The Specification Model — A Standard for Modular specifications, Open Geospatial Consortium, 2009